

铸铁系列

齿轮泵 齿轮马达

公司简介

毅鸥流体公司简介

上海毅鸥流体控制技术有限公司，前身为麦塔雷斯（上海）国际贸易有限公司，由加拿大METARIS公司在2001年注册成立于上海外高桥保税区，专业从事METARIS液压泵产品在中国市场的销售和服务。



随着市场需求的发展，麦塔雷斯（上海）于2007年起联合上海毅鸥流体控制技术有限公司共同运作，扩大海关外仓储容量，建立维修服务中心，并不断寻找和引进高性价比的进口液压产品，大大扩展了产品的可供性，提高了交货的及时性和维修服务能力。

到目前为止公司拥有的在中国市场全权代理的品牌，除了METARIS（麦塔雷斯），还有罗马尼亚HESPER（赫思博）和HYDRAULICA UM PLOPENI（普洛潘尼）的齿轮泵，齿轮马达，齿轮式同步马达；英国SLACK & PARR（斯奈克·派）高精度齿轮式同步马达，美国HARTMANN（哈特曼）的柱塞泵和美国ULTRA CLEAN（奥托克林）的管路清洗设备和污染控制产品。

毅鸥流体技术（YEOGO FLUID-TECH）作为多个品牌在中国市场的代言人，以诚信为本，向市场和用户推广和介绍各个品牌的优势产品，并努力以合理的价格，及时的交货和优质的服务，争取赢得市场和客户的信任。



METARIS公司简介

麦塔雷斯公司(METARIS INC.)成立于1952年，总部位于加拿大多伦多，是北美著名的叶片泵，齿轮泵和柱塞泵产品及零部件的供应商。以生产OEM替代产品为特色，与OEM产品 100% 互换。2013年被美国HYDRAULEX GLOBAL公司收购，2016年工厂搬迁到美国Memphis和Michigan。



产品概述	-----	4
主要技术参数	-----	5-12
轴端盖-安装法兰形式	-----	13-14
驱动轴标准和选项	-----	15-17
油口尺寸和标准	-----	18
产品参考尺寸	-----	19-24
产品参考重量	-----	25
产品系列及规格的认识	-----	26
MH25系列	-----	27-31
MH30/31系列	-----	32-35
MH37系列	-----	36-40
MH50/51系列	-----	41-44
MH75/76系列	-----	45-48
MH315系列	-----	49-50
MH330系列	-----	51-52
MH350系列	-----	53-54
MH365系列	-----	55-56
双联齿轮泵的类型与结构	-----	57
质保条款	-----	58

产品概述

麦塔雷斯的齿轮泵和马达主要应用于工程机械和石油，矿山机械。泵和马达的设计都充分考虑频繁的压力交变和连续重载等恶劣工况条件。产品设计可靠，制造工艺精良。

齿轮泵分单联泵和多联泵。输入轴和安装法兰有多种选择，可满足绝大部分用户的使用要求。进出口口具有公制、英制或美制的管螺纹连接方式和SAE拼合法兰连接方式。

麦塔雷斯生产的齿轮泵和马达受到质量保证体系ISO2002标准的严格控制。

产品特点：

- 1、组合式结构-采用高强度的铸铁泵壳，优质的齿轮，各种规格和连接尺寸的可选性能满足绝大部分用户的需求，维修备件在世界各地都有供应。
- 2、多联泵组合-在一根驱动轴上可串联几个同系列的泵组成同级多联泵，也可串联几个不同系列的泵(当选用的两泵之间排量差异很大时)组成异级多联泵。采用多联泵可减少驱动装置、紧凑安装位置，提高运转效率。
- 3、精密配对齿轮-所有齿轮均采用高合金棒料制造，表面经过精密加工。每对齿轮经过选配以确保最高的效率。采用10个齿的设计，使齿轮每转达到最大的输出效率。
- 4、轴承-轴承式齿轮泵和马达均采用特殊结构的优质滚针轴承，以减少由于污染的液压油造成的磨损。
- 5、轴瓦-轴瓦式齿轮泵和马达采用优质复合材料制造的轴瓦，轴瓦上有特氟龙涂层，使其具有更为理想的寿命。

产品系列：

- 1、轴承式齿轮泵和齿轮马达系列产品-包括15/20/25/30/31/37/50/51/75/76共10个系列，其中15/20系列没有列入本样本，客户如有需要请向本公司索取详细资料。
- 2、轴瓦式齿轮泵和齿轮马达(300系列)产品-包括315/330/350/365共4个系列。轴瓦式齿轮泵和马达更适应于高压和重载的工况。
- 3、自卸泵-包括MH101/MH102二个系列。运用于各种自卸式工程车辆。
- 4、齿轮式流量分配器-包括MFD30/31, 50/51, 75/76, 330, 350, 365共6个结构系列。运用于液压或润滑系统，实现精确、稳定的流量分配。详情请参考样本《齿轮流量分配器》。

产品的可替换性

麦塔雷斯齿轮泵和马达可以直接替换派克-柯莫索等公司的产品。其中的零部件也完全互换。

产品主要应用领域

- 建筑机械
- 采矿掘井和钻机设备
- 农业机械
- 油田钻井和修井设备
- 垃圾循环设备
- 注塑成形设备
- 岩石压碎，压力喷浆等设备
- 铲雪或盐沙展延机
- 密封包装机



主要技术参数-工作压力和排量

齿轮泵、马达的工作压力和排量

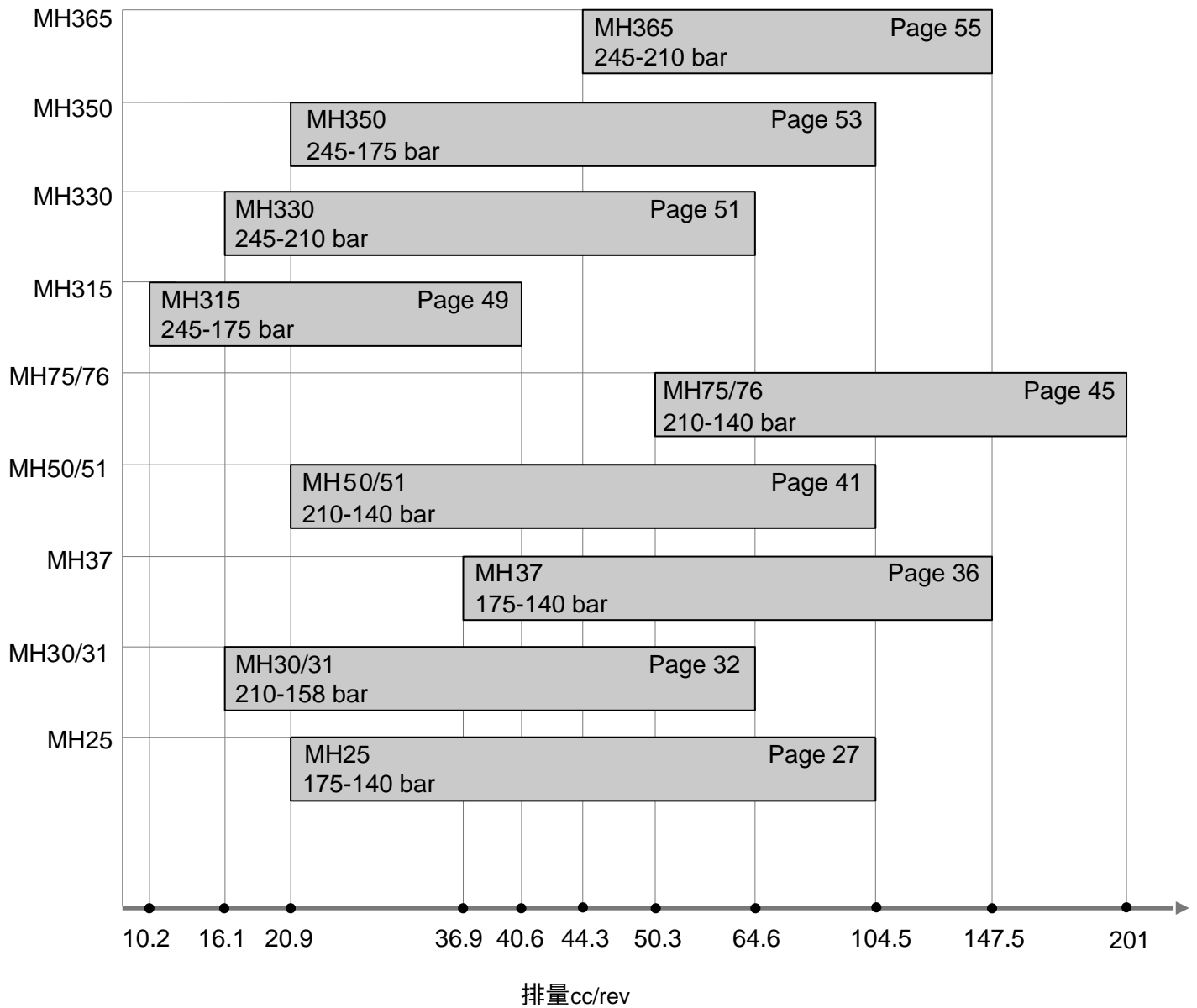

主要技术参数-工作压力和排量

齿轮泵、马达的工作压力和排量

齿宽单位：英寸 压力单位：bar 排量单位：cc/rev

齿轮规格		轴承式系列											
代码	齿宽	25		30		31		37		50		51	
		压力	排量	压力	排量	压力	排量	压力	排量	压力	排量	压力	排量
05	1/2"	175	20.9	175	16.1	210	16.1	-	-	175	20.9	210	20.9
07	3/4"	175	31.3	175	24.2	210	24.2	140	36.9	175	31.3	210	31.3
08	7/8"	-	-	-	-	-	-	-	-	-	-	-	-
10	1"	175	41.8	175	32.3	210	32.3	140	49.2	175	41.8	210	41.8
11	1-1/8"	-	-	-	-	-	-	-	-	-	-	-	-
12	1-1/4"	175	52.3	175	40.4	210	40.4	140	61.4	175	52.2	210	52.2
13	1-3/8"	-	-	-	-	-	-	-	-	-	-	-	-
15	1-1/2"	175	62.8	175	48.4	210	48.4	140	73.7	175	62.7	210	62.7
16	1-5/8"	-	-	-	-	-	-	-	-	-	-	-	-
17	1-3/4"	140	73.1	158	56.5	175	56.5	140	86.2	140	73.1	210	73.1
18	1-7/8"	-	-	-	-	-	-	-	-	-	-	-	-
20	2"	140	83.6	158	64.6	175	64.6	140	98.3	140	83.6	175	83.6
22	2-1/4"	140	94.0	-	-	-	-	140	110.6	140	94.0	175	94.0
25	2-1/2"	140	104.5	-	-	-	-	140	122.9	140	104.5	175	104.5
27	2-3/4"	-	-	-	-	-	-	-	-	-	-	-	-
30	3"	-	-	-	-	-	-	140	147.5	-	-	-	-
齿轮规格		轴承式系列						轴瓦式系列					
代码	齿宽	75		76		315		330		350		365	
		压力	排量	压力	排量	压力	排量	压力	排量	压力	排量	压力	排量
05	1/2"	-	-	-	-	245	10.2	245	16.1	245	20.9	-	-
07	3/4"	175	50.28	210	50.28	245	15.2	245	24.2	245	31.3	245	44.3
08	7/8"	-	-	-	-	-	-	-	-	-	-	-	-
10	1"	175	67.15	210	67.15	245	20.3	245	32.3	245	41.8	245	59.0
11	1-1/8"	-	-	-	-	-	-	-	-	-	-	-	-
12	1-1/4"	175	83.85	210	83.85	245	25.4	245	40.4	245	52.2	245	73.8
13	1-3/8"	-	-	-	-	-	-	-	-	-	-	-	-
15	1-1/2"	175	100.7	210	100.7	231	30.5	245	48.4	245	62.7	245	88.5
16	1-5/8"	-	-	-	-	-	-	-	-	-	-	-	-
17	1-3/4"	175	117.45	210	117.45	203	35.6	228	56.5	228	73.1	245	103.3
18	1-7/8"	-	-	-	-	-	-	-	-	-	-	-	-
20	2"	175	134.3	175	134.3	175	40.6	210	64.6	210	83.6	245	118.0
22	2-1/4"	158	151	175	151	-	-	-	-	193	94.0	228	132.8
25	2-1/2"	158	167.8	175	167.8	-	-	-	-	175	104.5	210	147.5
27	2-3/4"	140	185	140	185	-	-	-	-	-	-	-	-
30	3"	140	201	140	201	-	-	-	-	-	-	-	-

主要技术参数-泵的参考转速和流量

轴承式系列齿轮泵的参考转速和流量

产品系列	转速 转/分钟	代码和齿宽(英寸)										
		05 (1/2")	07 (3/4")	10 (1")	12 (1-1/4")	15 (1-1/2")	17 (1-3/4")	20 (2")	22 (2-1/4")	25 (2-1/2")	27 (2-3/4")	30 (3")
		流量(公升/分钟) 在175bar压力条件下										
37	600	-	-	17	25	32	40	47	53	62	-	76
30/31/37	900	12.2	18.5	24.5	30	38	45.5	51	-	-	-	-
25、50/51		16	24	32	39.5	49	57	66	75.5	83.5	-	-
75/76		-	32.5	43.5	58.5	74	87	102	115.5	130.5	144	159
37	1200	-	-	47	62	76	91	106	119	134	-	163
30/31		17	25.5	34	43.5	53	60.5	70	-	-	-	-
25、50/51		22.5	34	46.5	57	68	79.5	91	102	114	-	-
75/76		-	48	64.5	83.5	102	121	142	159	182	199	220
30/31/37	1500	21.5	32.5	43.5	55	66	77.5	89	-	-	-	-
25、50/51		28	42.5	57	72	87	102	117	132	146	-	-
75/76		-	62	83.5	110	134	157	182	206	231	254	280
37	1800	-	-	76	98	119	142	165	187	208	-	252
30/31		26.5	40	53	68	81.5	94.5	110	-	-	-	-
25、50/51		34	51	68	87	104	123	142	159	178	-	-
75/76		-	77.5	104	134	165	193	223	250	280	308	341
37	2100	-	-	91	117	142	168	193	219	244	-	295
30/31		31	46.5	62.5	79.5	94.5	112	129	-	-	-	-
25、50/51		40	60.5	81.5	102	123	146	167	187	208	-	-
75/76		-	93	125	159	195	227	263	295	329	365	401
37	2400	-	-	106	136	165	193	223	254	282	-	341
30/31		36	53.8	72	91	110	129	148	-	-	-	-
25、50/51		47	70.5	94.5	117	140	167	193	216	240	-	-
75/76		-	107	144	185	225	265	303	341	382	420	462

主要技术参数-泵的参考转速和流量

轴瓦式系列齿轮泵的参考转速和流量

产品系列	转速 转/分钟	代码和齿宽(英寸)								
		05 (1/2")	07 (3/4")	10 (1")	12 (1-1/4")	15 (1-1/2")	17 (1-3/4")	20 (2")	22 (2-1/4")	25 (2-1/2")
		流量(公升/分钟) 在175bar压力条件下								
315	900	8	12	17	21	26	30	34	-	-
330		12	19	26	33	40	47	54	-	-
350		15	24	33	42	52	61	70	70	90
365		-	30	44	57	70	83	96	109	122
315	1200	11	17	23	29	35	40	46	-	-
330		17	26	36	45	55	64	73	-	-
350		21	33	46	58	71	83	95	108	120
365		-	44	61	79	96	114	131	149	166
315	1500	14	21	29	36	44	51	58	-	-
330		22	34	46	57	69	81	93	-	-
350		28	43	59	74	89	105	120	136	151
365		-	57	79	101	123	145	167	188	211
315	1800	17	26	35	44	53	62	70	-	-
330		27	41	55	70	84	98	112	-	-
350		34	52	71	89	108	127	145	164	183
365		-	70	97	123	149	176	202	228	255
315	2100	20	30	41	51	62	72	83	-	-
330		32	48	65	82	98	115	131	-	-
350		40	62	84	105	127	149	171	192	214
365		-	83	114	145	176	207	238	268	299
315	2400	23	35	47	59	71	83	95	-	-
330		36	55	75	94	113	132	151	-	-
350		46	71	96	121	146	171	196	220	245
365		-	97	132	167	203	238	273	308	343
315	3000	29	44	59	74	90	104	119	-	-
330		46	70	94	118	142	166	190	-	-

主要技术参数-泵的平均输入功率

轴承式系列齿轮泵在对应额定压力条件下的平均输入功率

产品系列	转速 转/分钟	代码和齿宽 (英寸)								
		10 (1")	12 (1-1/4")	15 (1-1/2")	17 (1-3/4")	20 (2")	22 (2-1/4")	25 (2-1/2")	27 (2-3/4")	30 (3")
轴承式系列泵的平均输入功率 (kw)										
30/31	900	11	13	15	17	19	-	-	-	-
25、50/51		14	17	20	23	26	29	32	-	-
75/76		19	24	29	34	38	43	48	42	46
30/31	1200	14	17	20	22	25	-	-	-	-
25、50/51		18	22	26	30	34	38	42	-	-
75/76		26	32	39	45	51	58	64	57	62
30/31	1500	17	21	24	27	31	-	-	-	-
25、50/51		23	27	32	37	42	47	51	-	-
75/76		33	41	49	57	65	73	81	72	78
30/31	1800	20	25	29	33	37	-	-	-	-
25、50/51		27	33	38	44	50	56	61	-	-
75/76		39	49	59	69	79	89	99	87	95
30/31	2100	24	29	34	38	43	-	-	-	-
25、50/51		31	38	44	51	58	65	72	-	-
75/76		46	58	69	81	92	104	115	101	111
30/31	2400	26	33	38	43	49	-	-	-	-
25、50/51		35	43	51	59	66	74	82	-	-
75/76		53	66	79	92	105	118	132	116	126



主要技术参数-泵的平均输入功率

轴瓦式系列齿轮泵在对应额定压力条件下的平均输入功率

产品系列	转速 转/分钟	代码和齿宽(英寸)						
		10 (1")	12 (1-1/4")	15 (1-1/2")	17 (1-3/4")	20 (2")	22 (2-1/4")	25 (2-1/2")
		轴瓦式系列泵的平均输入功率(kw)						
315	900	4	6	8	10	11	-	-
330		6	10	13	16	19	-	-
350		8	12	17	21	25	27	28
365		-	18	23	29	35	41	47
315	1200	5	8	11	13	15	-	-
330		8	13	17	21	25	-	-
350		11	17	22	28	33	36	38
365		-	23	31	39	47	55	63
315	1500	7	10	13	16	19	-	-
330		11	16	21	26	32	-	-
350		14	21	28	34	41	45	47
365		-	29	39	49	59	68	78
315	1800	8	12	16	20	22	-	-
330		13	19	25	32	38	-	-
350		17	25	33	41	50	54	57
365		-	35	47	59	70	82	94
315	2100	9	14	18	23	26	-	-
330		15	22	30	37	44	-	-
350		19	29	39	48	58	63	66
365		-	41	55	68	82	96	110
315	2400	11	16	21	26	30	-	-
330		17	25	34	42	51	-	-
350		22	33	44	55	66	72	76
365		-	47	63	78	94	110	125
315	3000	13	20	26	33	37	-	-
330		21	32	42	53	64	-	-

主要技术参数-马达的输入流量和输出扭矩

轴承式齿轮马达的输入流量和输出扭矩

D-输入流量（公升/分钟） E-输出扭矩（牛顿·米）

产品系列	转速 转/分钟	代码和齿宽（英寸）									
		10 (1")		15 (1-1/2")		20 (2")		25 (2-1/2")		30 (3")	
		D	E	D	E	D	E	D	E	D	E
31系列 输入压力 175bar	800	34	77	49	118	64.5	157	-	-	-	-
	1200	49	77	68	118	89	157	-	-	-	-
	1600	60.5	77	87	116	115	157	-	-	-	-
	2000	74	75	106	114	140	155	-	-	-	-
25/50系列 输入压力 140bar	800	39.5	76	58.5	121	79.5	164	98.5	208	-	-
	1200	58.5	77	85	121	115	164	142	208	-	-
	1600	75.5	75	114	118	151	162	187	198	-	-
	2000	94.5	74	140	114	185	160	233	195	-	-
51系列 输入压力 175bar	800	39.5	93	58.5	148	79.5	205	98.5	264	-	-
	1200	58.5	96	85	151	115	207	142	264	-	-
	1600	75.5	93	114	151	151	207	187	260	-	-
	2000	94.5	90	140	146	185	200	233	254	-	-
37系列 输入压力 140bar	900	40	83	57	132	76	186	93	240	106	299
	1200	61	83	87	132	117	182	144	235	167	294
	1500	79	83	117	132	155	182	193	235	227	294
	1800	100	78	147	128	197	176	242	230	288	288
75系列 输入压力 140bar	800	77.5	118	106	186	134	248	163	323	191	410
	1200	104	116	144	181	187	248	229	323	273	404
	1600	129	113	185	178	242	245	297	316	352	395
	2000	157	108	223	175	295	245	365	310	431	387
76系列 输入压力 175bar	800	77.5	158	106	242	134	325	163	412	191	495
	1200	104	158	144	242	187	325	229	412	273	495
	1600	129	155	185	238	242	319	297	406	352	487
	2000	157	152	223	236	295	319	365	395	431	473

主要技术参数-马达的输入流量和输出扭矩

轴瓦式齿轮马达的输入流量和输出扭矩

D-输入流量（公升/分钟） E-输出扭矩（牛顿·米）

输入压力 产品系列	转速 转/分钟	代码和齿宽（英寸）													
		10(1")		12(1-1/4")		15(1-1/2")		17(1-3/4")		20(2")		22(2-1/4")		25(2-1/2")	
		D	E	D	E	D	E	D	E	D	E	D	E	D	E
315系列		245bar		245bar		228bar		203bar		175bar		-		-	
	900	27	75	32	94	37	105	41	109	46	107	-	-	-	-
	1200	33	75	40	94	46	105	52	109	59	107	-	-	-	-
	1500	40	75	48	93	56	104	63	108	71	107	-	-	-	-
	1800	46	74	56	93	65	103	74	107	84	106	-	-	-	-
	2100	53	74	64	93	75	103	85	107	96	106	-	-	-	-
	2400	59	72	72	90	84	101	96	105	109	104	-	-	-	-
3000	72	72	87	90	103	101	118	105	134	103	-	-	-	-	
330系列		245bar		245bar		245bar		228bar		210bar		-		-	
	900	38	114	47	144	55	173	63	188	72	200	-	-	-	-
	1200	49	114	59	143	70	172	81	188	92	199	-	-	-	-
	1500	59	113	72	142	85	171	99	186	112	198	-	-	-	-
	1800	69	112	85	141	101	170	116	185	132	197	-	-	-	-
	2100	80	112	98	140	116	169	134	184	152	194	-	-	-	-
	2400	90	111	111	140	131	167	152	181	172	192	-	-	-	-
3000	110	111	136	139	161	167	186	180	212	190	-	-	-	-	
350系列		245bar		245bar		245bar		228bar		210bar		193bar		175bar	
	900	51	149	61	189	70	229	80	251	90	266	100	274	110	277
	1200	64	149	77	188	90	228	103	250	116	264	129	272	142	275
	1500	77	147	93	185	110	225	126	248	142	262	158	270	174	272
	1800	91	146	110	185	129	223	148	246	167	260	187	268	206	271
	2100	104	145	126	183	149	222	171	245	193	258	216	266	238	269
	2400	117	143	143	181	168	219	194	241	219	255	245	263	270	266
365系列		245bar		245bar		245bar		228bar		210bar		193bar		175bar	
	900	70	211	83	266	97	323	111	381	124	435	138	454	152	466
	1200	88	209	106	263	124	320	142	377	160	431	179	450	197	461
	1500	107	205	129	259	152	314	174	371	197	424	219	442	242	454
	1800	125	204	152	257	179	312	206	369	233	421	260	440	287	451
	2100	144	198	175	250	206	304	238	357	269	408	300	426	332	437
	2400	162	193	198	244	234	296	269	345	305	394	341	412	377	423

轴端盖-安装法兰形式

常用安装法兰形式的图形和尺寸

代码00 - 托板式安装

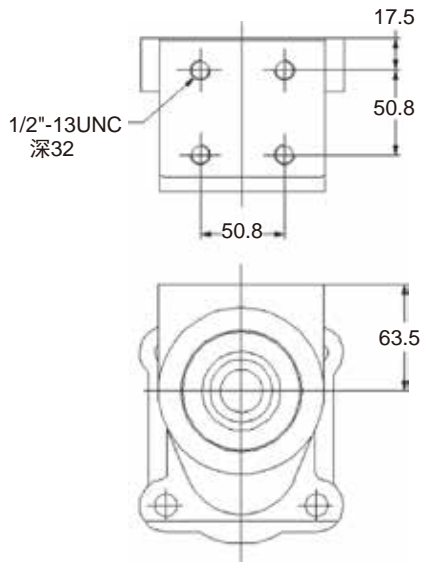

代码05 - 6螺栓圆法兰安装

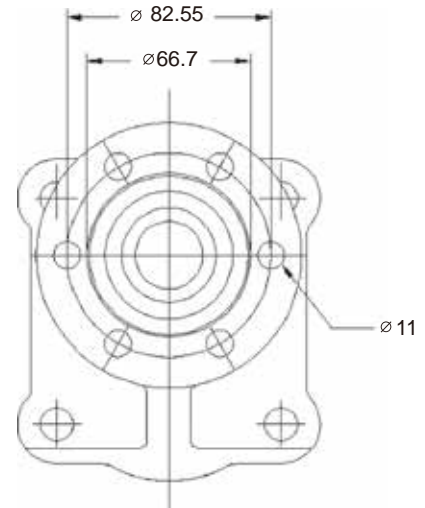

代码42 - SAE 4螺栓B型安装

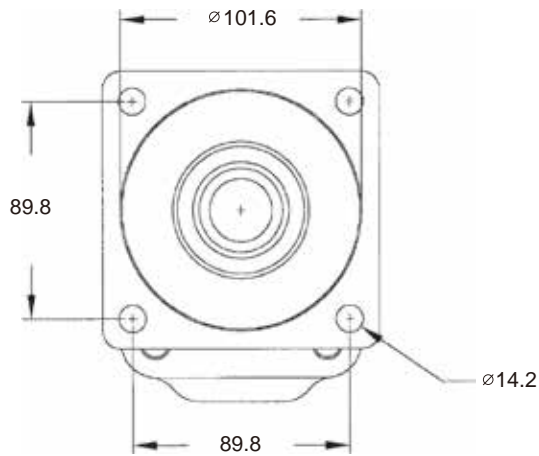

代码46 - SAE 2/4螺栓B型安装

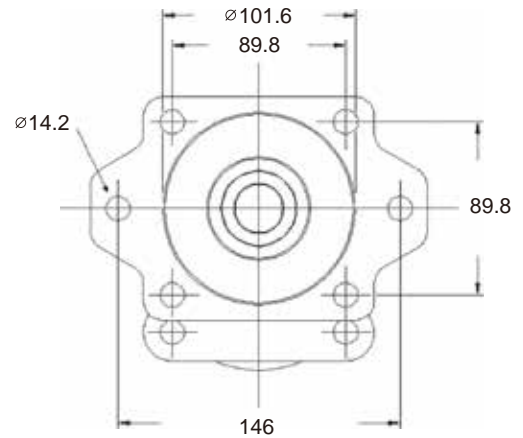

轴端盖-安装法兰形式

常用安装法兰形式的图形和尺寸

代码78 - SAE 4螺栓C型安装

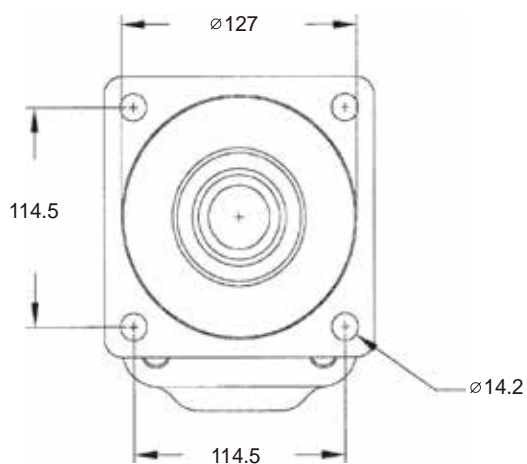

代码94 - SAE 2螺栓A型安装

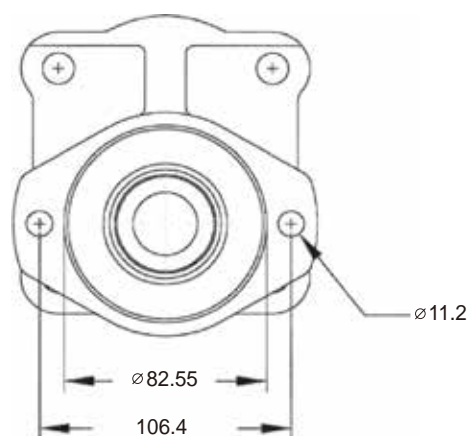

代码97 - SAE 2螺栓B型安装

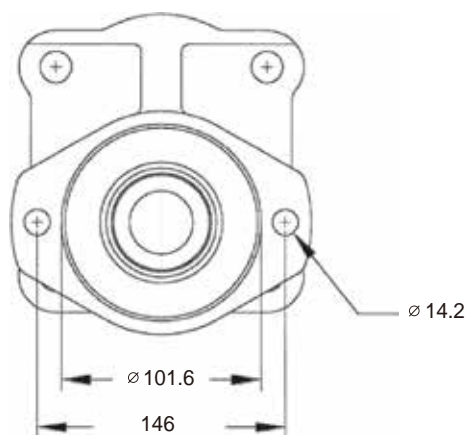

代码98 - SAE 2螺栓C型安装

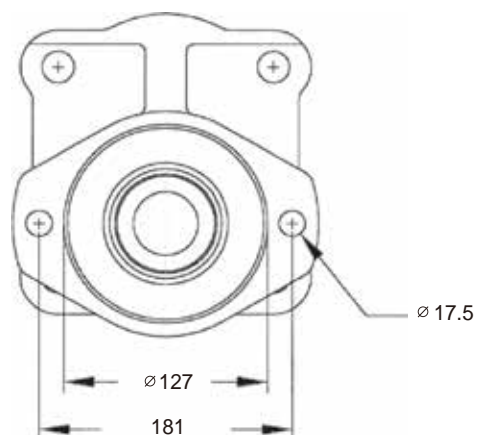

驱动轴标准和选项

泵输入轴的PL系数校核：

当设计选用一个多联泵时，需对所选用的驱动轴的强度进行校核。因为一个多联泵、马达的各单元的对应功率要求是通过一个驱动轴来提供的。采用轴的PL系数进行校核，可以十分方便地通过简单计算确保所选用驱动轴的工作强度。

强度校核方法：

- 1、从下表中查阅所选的驱动轴的对应PL系数。
- 2、计算多联泵、马达的（PL）系数： $(PL) = \sum \text{齿轮宽度（英寸）} \times \text{工作压力（psi）}$
- 3、安全强度要求： $(PL) \leq PL$

产品系列	轴的形式	轴的标准								多联泵的连接轴
		SAE“A”型 花键轴	SAE“A”型 平键轴	SAE“BB”型 花键轴	SAE“BB”型 平键轴	SAE“B”型 花键轴	SAE“B”型 平键轴	SAE“C”型 花键轴	SAE“C”型 平键轴	
30/31	整体式	—	—	13000	8600	8300	5700	—	—	—
	两件式	—	—	5500	5500	5500	5500	—	—	5500
37	两件式	—	—	7750	5550	5050	3700	11950	11950	11950
50/51	整体式	—	—	9900	6600	6400	5750	13850	13000	—
	两件式	—	—	8000	6600	6400	5750	8000	8000	8000
75/76	整体式	—	—	7750	5550	5050	3700	8600	8300	—
	两件式	—	—	7750	5550	5050	3700	7750	7750	7750
315	整体式	4450	3600	—	—	13400	9900	—	—	—
	两件式	—	—	—	—	—	—	—	—	5550
330	整体式	—	—	13000	9300	8450	6250	—	—	—
	两件式	—	—	6250	6250	6250	6250	6250	6250	6250
350	整体式	—	—	9900	7100	6450	4750	19100	13900	—
	两件式	—	—	9000	7100	6450	4750	9000	9000	9000
365	整体式	—	—	7750	5550	5050	3700	14900	10800	—
	两件式	—	—	7750	5550	5050	3700	11950	10800	11950

常用的驱动轴形式和尺寸列举如下：

代号07

SAE“C”型花键-ANSI 32-4

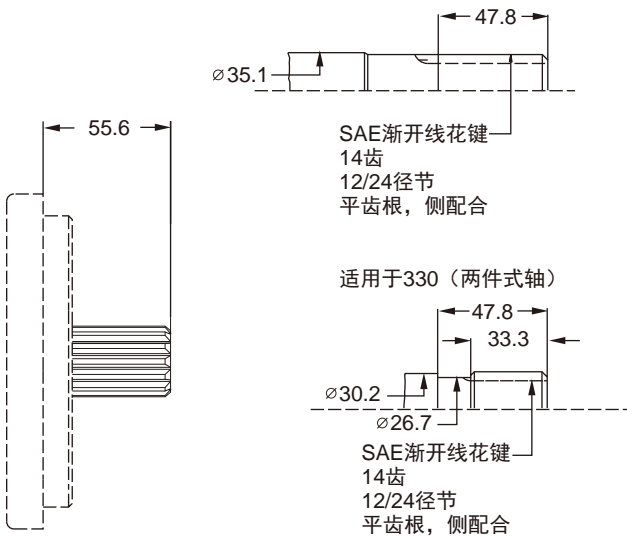

代号11

SAE“C”型平键-ANSI 32-1

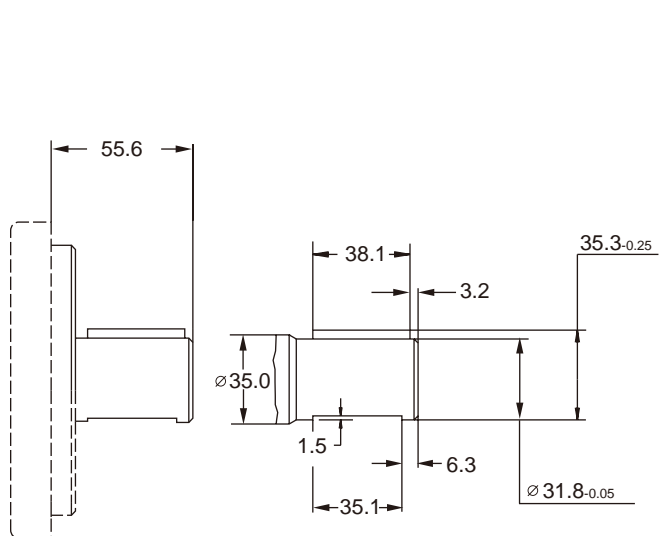

驱动轴标准和选项

代号25

SAE“B”型花键-13齿ANSI 22-4

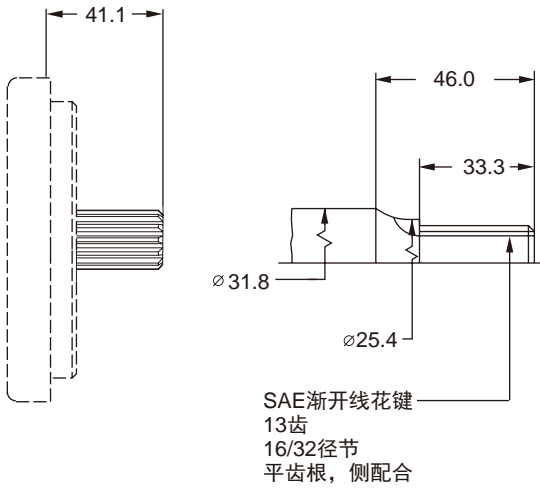

代号30

SAE“B”型平键-ANSI 22-1

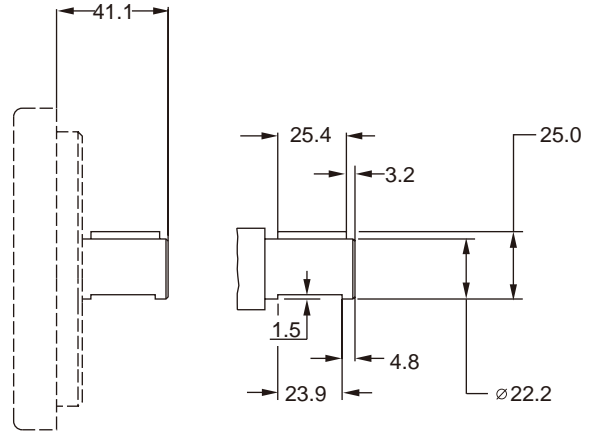

代号43

SAE“BB”型平键-ANSI 25-1

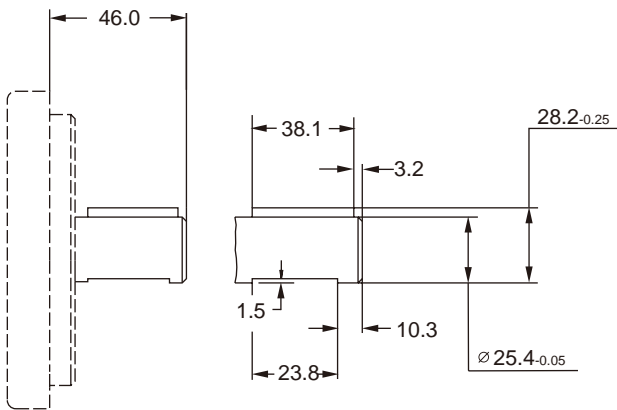

代号65

SAE“B”型花键-13齿ANSI 22-4

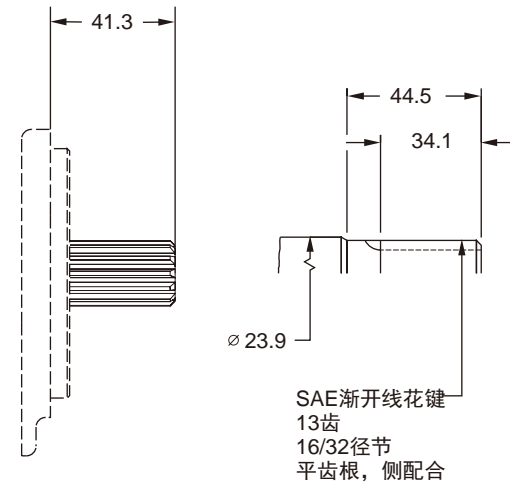

代号66

SAE“B”型平键-ANSI 22-1

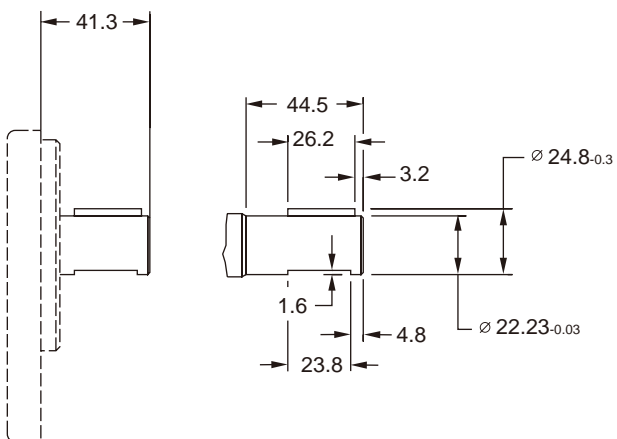

代号96

SAE“A”型花键-9齿ANSI 16-4

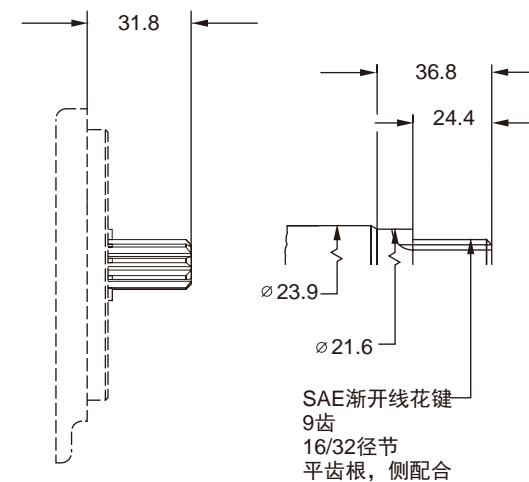

驱动轴标准和选项

代号97
SAE“A”型平键-ANSI 16-1

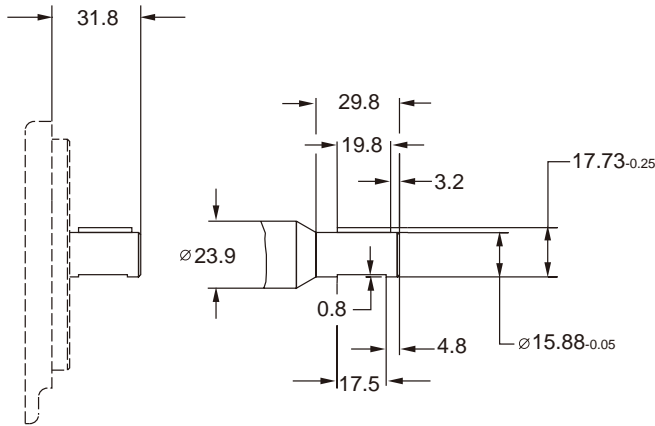

代号98
SAE“BB”型花键-15齿ANSI 25-4

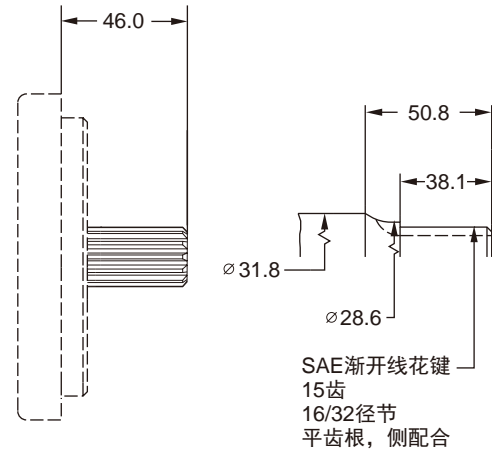

齿轮泵常用驱动轴的形式汇总:

代码	主轴形式	产品系列								
		25	30/31	37	50/51	75/76	315	330	350	365
03	6齿花键-1.1096"大径x2-1/8"轴伸									
07	SAE“C”型14齿花键-1.25"大径	✓	✓	✓	✓	✓		✓	✓	✓
11	SAE“C”型平键-1.25"轴径, 5/16"x15/32"x1-1/2"键	✓		✓	✓	✓			✓	✓
25	SAE“B”型13齿花键-0.88"大径		✓	✓	✓			✓	✓	
30	SAE“B”型平键-0.88"轴径, 1/4"x3/8"x1"键	✓	✓	✓				✓		
38	平键-0.8745"轴径, 1-7/16"轴伸, 1-1/4"键	✓								
39	平键-0.8745"轴径, 2-5/16"轴伸	✓								
43	SAE“BB”型平键-1"轴径, 1/4"x3/8"x1-1/4"键	✓	✓		✓			✓		
45	平键-0.8745"轴径, 2-13/32"轴伸, 1-1/4"键2型	✓								
47	平键-0.9996"轴径, 1-1/4"键2型	✓								
48	SAE“B”型13齿花键, 2型	✓								
53	SAE“C”型14齿花键-1.25"大径	✓								
61	平键-1.25"轴径, 1-1/2"键2型	✓								
65	SAE“B”型13齿花键-0.88"大径2型		✓		✓		✓			
66	SAE“B”型平键-0.88"轴径, 1/4"x3/8"x1"键2型		✓				✓			
73	SAE“C”型平键-1.25"轴径, 5/16"x15/32"x2-1/4"键	✓		✓						
76	平键-0.999"轴径, 1-1/2"键3型	✓								
90	SAE“B”型平键带5/8"-18螺纹-0.88"轴径									
95	SAE“A”型9齿花键-0.62"大径									
96	SAE“A”型9齿花键						✓			
97	SAE“A”型平键						✓			
98	SAE“BB”型15齿花键-1"大径						✓	✓		

油口尺寸和标准

螺纹油口

油口规格 (英制)	NPT 符合ANSI.B1.20	SAE O型圈密封 符合ISO11926	BSPB 符合ISO1179	公制螺纹 符合ISO6149-2
1/4"	1/4"-18	-	1/4"-19	-
3/8"	3/8"-18	-	3/8"-19	-
1/2"	1/2"-14	3/4"-16UNF	1/2"-14	M18×1.5
5/8"	-	7/8"-14UNF	-	M22×1.5
3/4"	3/4"-14	1-1/16"-12UN	3/4"-14	M26×1.5
7/8"	-	1-3/16"-12UN	-	M30×1.5
1"	1"-11.5	1-5/16"-12UN	1"-11	M33×2
1-1/4"	1-1/4"-11.5	1-5/8"-12UN	1-1/4"-11	M42×2
1-1/2"	1-1/2"-11.5	1-7/8"-12UN	1-1/2"-11	M48×2
2"	-	2-1/2"-12UN	2"-11	-
2-1/2"	-	-	-	-
3"	-	-	-	-

SAE拼合法兰油口-符合SAE标准-标准系列（代码61）

油口规格 (英制)	A	B	C (美制螺栓)	C (公制螺栓)	D
1/2"	38.1	17.5	5/16"-18UNC	M8×1.25	15
3/4"	47.6	22.2	3/8"-16UNC	M10×1.5	18
1"	52.2	26.2	3/8"-16UNC	M10×1.5	18
1-1/4"	58.7	30.2	7/16"-14UNC	M10×1.5	22
1-1/2"	69.9	35.7	1/2"-13UNC	M12×1.75	26
2"	77.8	42.9	1/2"-13UNC	M12×1.75	26
2-1/2"	88.9	50.8	1/2"-13UNC	M12×1.75	26



图1 SAE拼合法兰油口



图2 螺栓孔剖面图

注：如需特殊油口，请向上海毅鸥公司咨询。

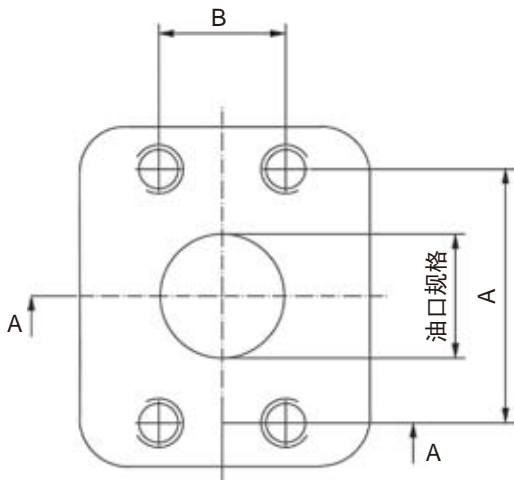
产品参考尺寸-MH25

MH25系列单联泵

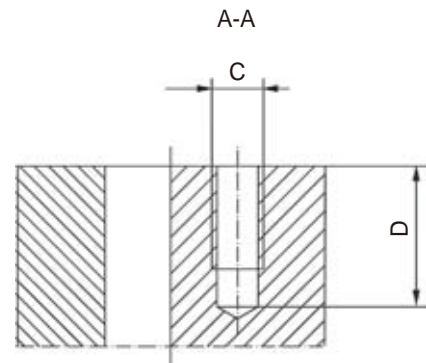
单位: mm

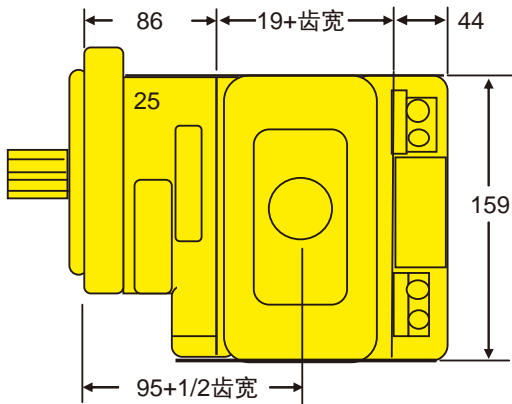

主视图

注: 主轴伸出尺寸随主轴选型不同而变化

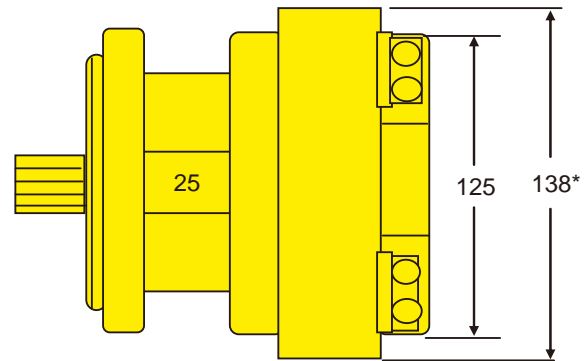

俯视图

注: 138*该尺寸随油口选型不同而变化

MH25系列多联泵

单位: mm

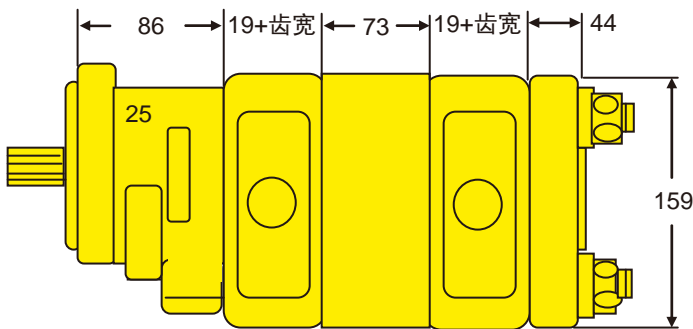

主视图

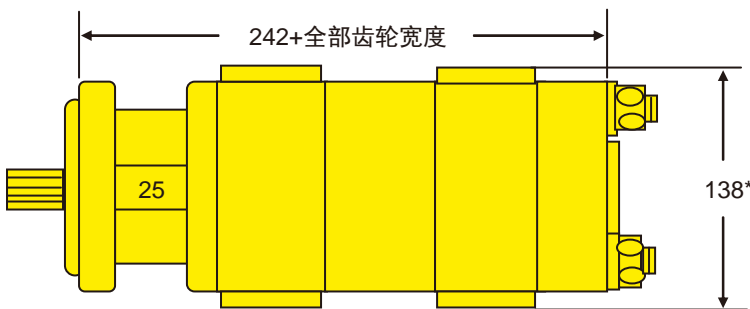

俯视图

注: 138*该尺寸随油口选型不同而变化

注: • 本页所有尺寸为外形尺寸, 仅供参考
• 铸件设计尺寸可能变化, 恕不通知

产品参考尺寸-MH30/31

MH30/31系列单联泵

单位：mm

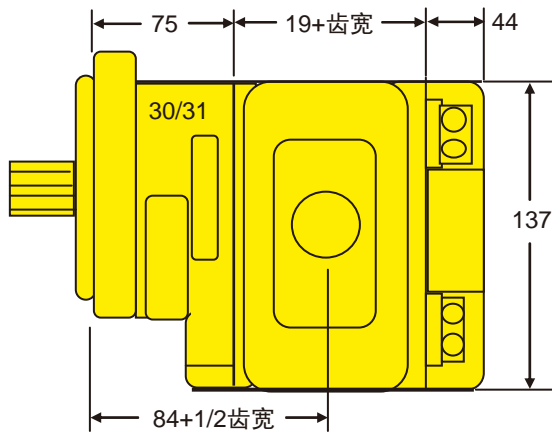

主视图

注：主轴伸出尺寸随主轴选型不同而变化

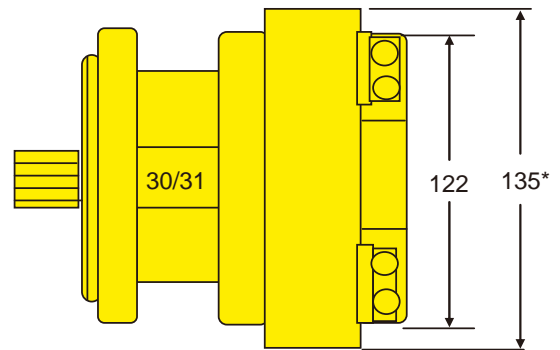

俯视图

注：135*该尺寸随油口选型不同而变化

MH30/31系列多联泵

单位：mm

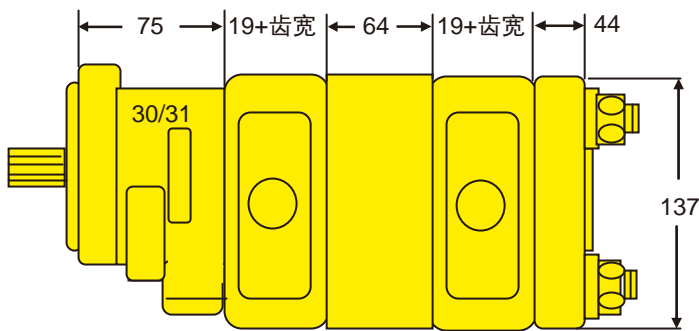

主视图

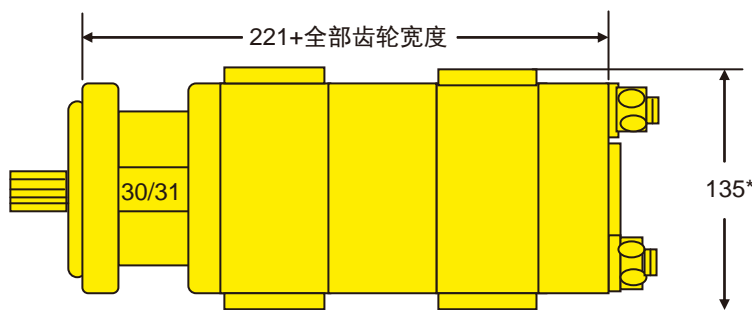

俯视图

注：135*该尺寸随油口选型不同而变化

注：
• 本页所有尺寸为外形尺寸，仅供参考
• 铸件设计尺寸可能变化，恕不通知

产品参考尺寸-MH37

MH37系列单联泵

单位：mm

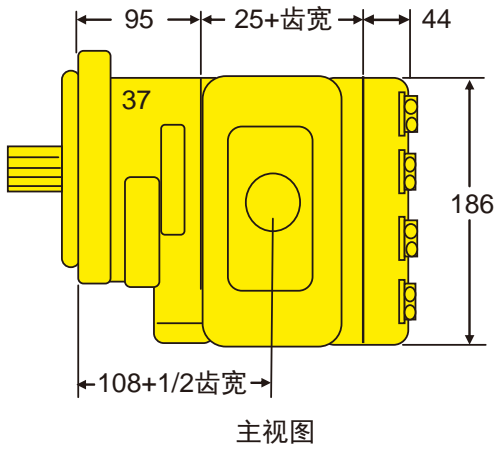

注：主轴伸出尺寸随主轴选型不同而变化

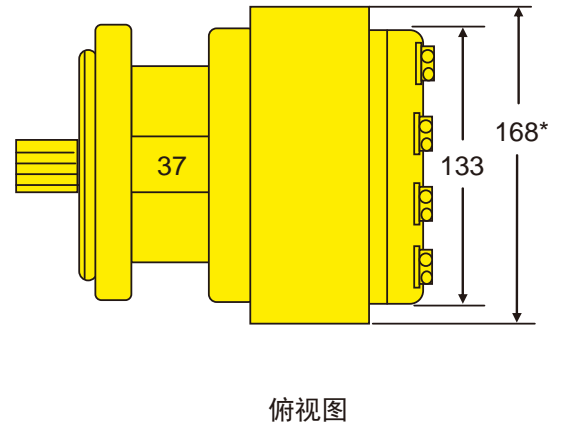

注：168*该尺寸随油口选型不同而变化

MH37系列多联泵

单位：mm

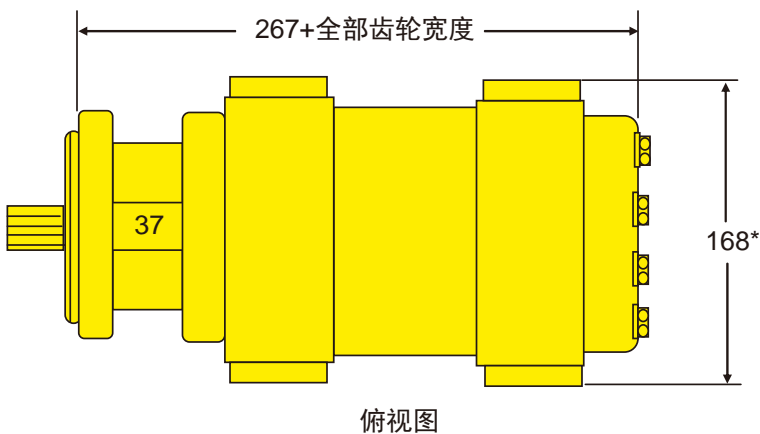
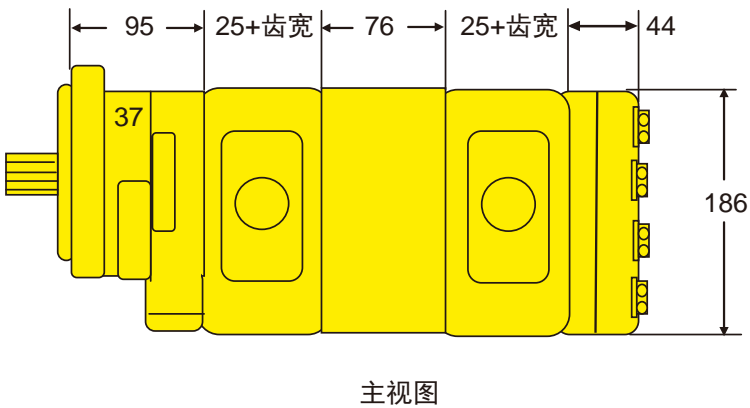

注：168*该尺寸随油口选型不同而变化

注：
• 本页所有尺寸为外形尺寸，仅供参考
• 铸件设计尺寸可能变化，恕不通知

产品参考尺寸-MH50/51

MH50/51系列单联泵

单位：mm

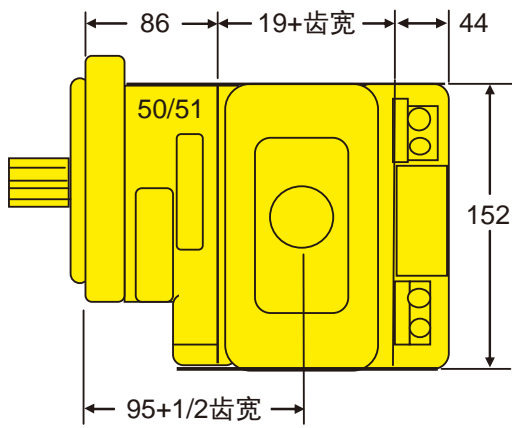

主视图

注：主轴伸出尺寸随主轴选型不同而变化

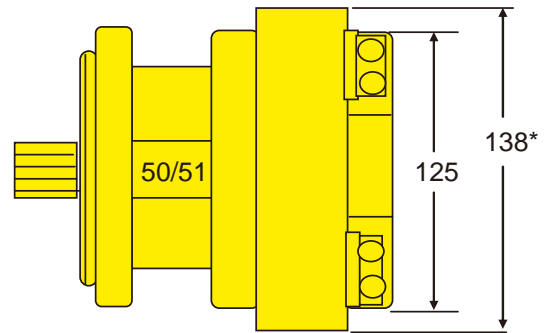

俯视图

注：138*该尺寸随油口选型不同而变化

MH50/51系列多联泵

单位：mm

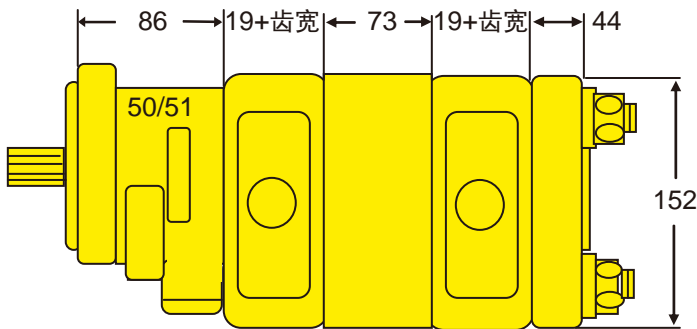

主视图

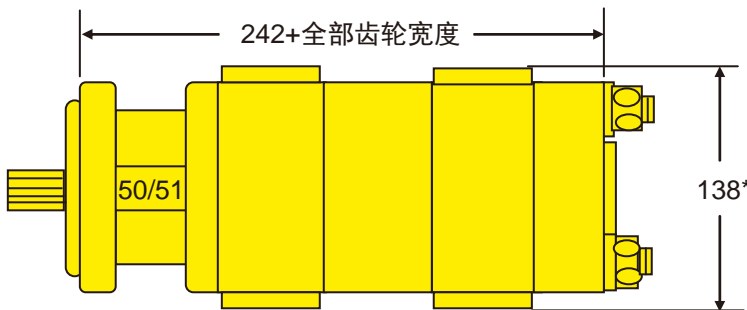

俯视图

注：138*该尺寸随油口选型不同而变化

注：• 本页所有尺寸为外形尺寸，仅供参考
• 铸件设计尺寸可能变化，恕不通知

产品参考尺寸-MH75/76

MH75/76系列单联泵

单位：mm

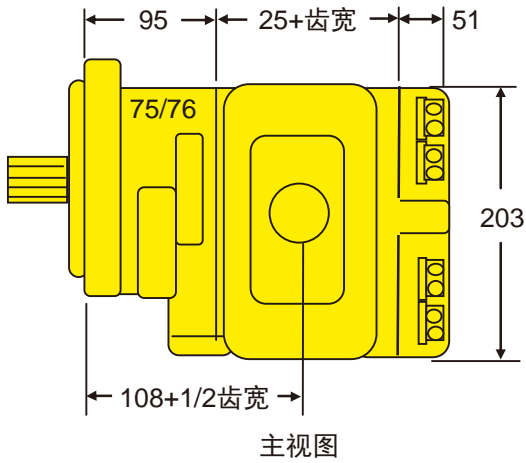

注：主轴伸出尺寸随主轴选型不同而变化

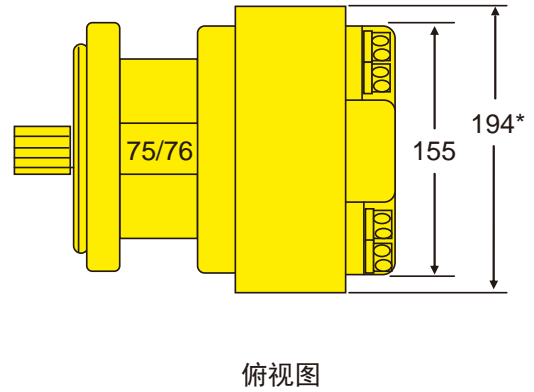

注：194*该尺寸随油口选型不同而变化

MH75/76系列多联泵

单位：mm

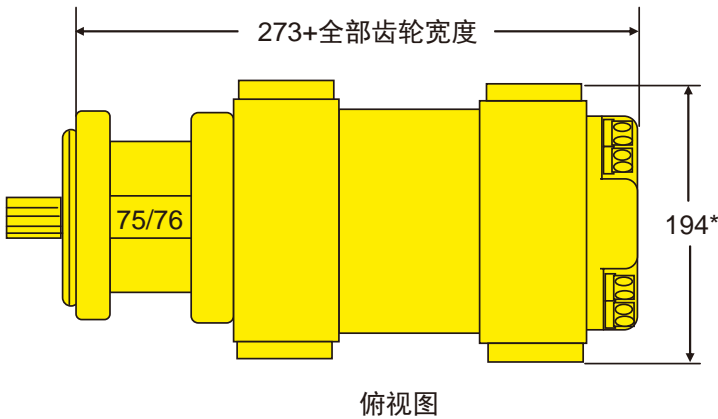
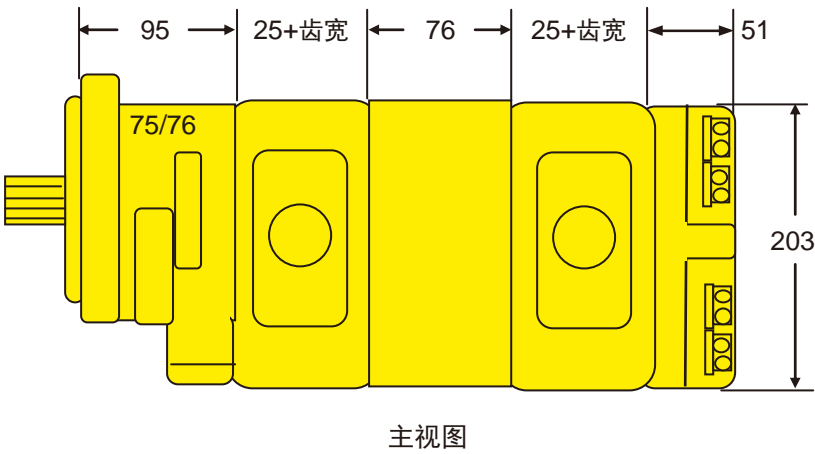

注：194*该尺寸随油口选型不同而变化

注：• 本页所有尺寸为外形尺寸，仅供参考
• 铸件设计尺寸可能变化，恕不通知

产品参考尺寸-MH300系列

MH300系列单联泵、马达

单位: mm

系列	L	H	W*	C	D	E	F
315	102.2+GW	121	127	48	10.2+GW	44	102
330	148.5+GW	149	172	79	12.5+GW	57	122
350	158.5+GW	152	195	89	12.5+GW	57	146
365	174.5+GW	184	213	95	12.5+GW	67	159

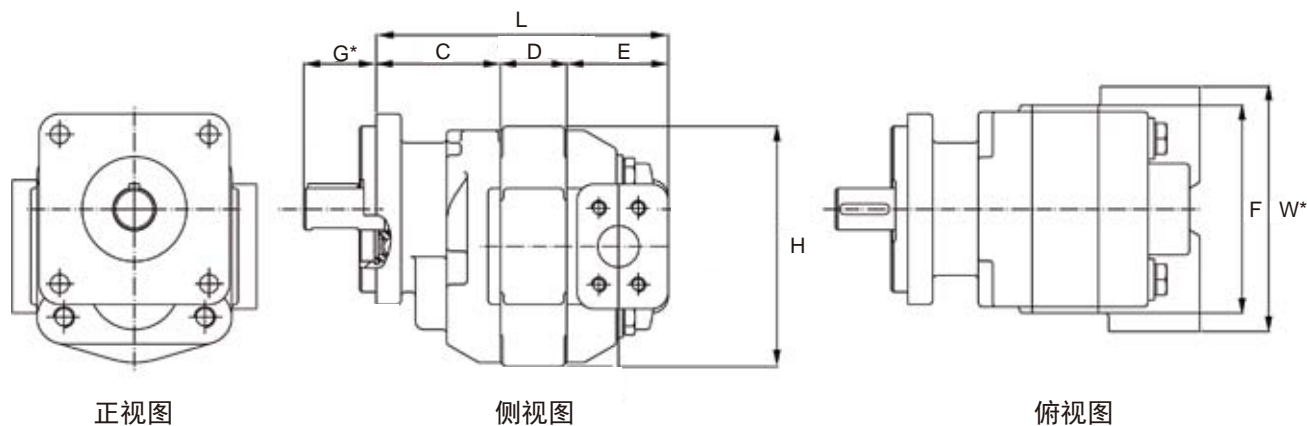

MH300系列多联泵、马达

单位: mm

系列	L	H	W*	C	D	I	E	J	K	M
315	$92+67 \cdot (N-1)+D_1+D_2+\dots+D_n$	121	127	48	10.2+GW	67	44	91.5+GW	9	47
330	$136+89 \cdot (N-1)+D_1+D_2+\dots+D_n$	149	172	79	12.5+GW	89	57	136+GW	16	60
350	$146+89 \cdot (N-1)+D_1+D_2+\dots+D_n$	152	195	89	12.5+GW	89	57	146+GW	13	64
365	$162+102 \cdot (N-1)+D_1+D_2+\dots+D_n$	184	213	95	12.5+GW	102	67	159+GW	16	73

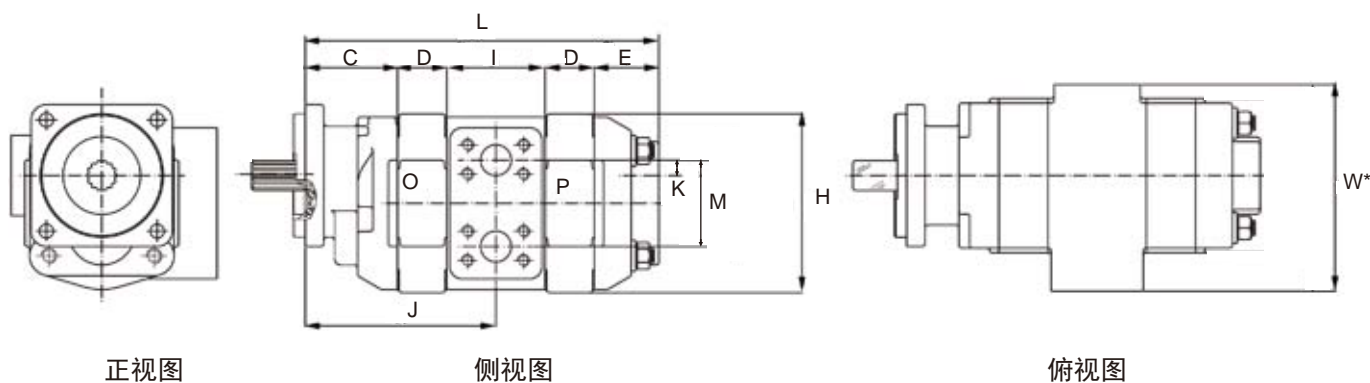

- 注:
- GW=齿轮宽度
 - N=多联单元数量
 - 本页所有尺寸为外形尺寸, 仅供参考

- W*随油口类型而变化
- G*随选用的驱动轴不同而变化
- 铸件设计尺寸可能变化, 恕不通知

产品参考重量

单联泵、马达的参考重量

重量单位: kg

产品系列	齿宽规格										
	1/2"	3/4"	1"	1-1/4"	1-1/2"	1-3/4"	2"	2-1/4"	2-1/2"	2-3/4"	3"
MH25	16.3	17.7	19.1	19.7	20.4	21.1	21.8	22.7	23.6	—	—
MH30/31	13.6	14.1	14.5	15	15.4	15.9	16.3	—	17.5	—	—
MH37	23.6	24.5	25.4	26.3	27.2	28.1	29.5	30.9	32.2	—	35.4
MH50/51	16.8	18.2	19.5	20.2	20.9	21.6	22.2	23.2	24.3	—	—
MH75/76	30.4	31.8	32.7	33.6	34.5	35.9	37.2	38.6	40	—	41.8
MH315	7.3	7.7	8.2	8.6	9.1	9.5	10	—	—	—	—
MH330	—	15.8	16.3	16.9	17.5	18	18.6	19.2	19.7	—	—
MH350	—	22.5	23.2	23.8	24.5	25.2	25.9	26.6	27.2	—	—
MH365	—	—	25.4	26.6	27.7	28.8	30	31.1	32.2	33.4	34.5

多联泵、马达每增加一联的参考重量

重量单位: kg

产品系列	齿宽规格										
	1/2"	3/4"	1"	1-1/4"	1-1/2"	1-3/4"	2"	2-1/4"	2-1/2"	2-3/4"	3"
MH25	12.9	13.6	14.3	15	15.7	16.3	16.8	18.6	20	—	—
MH30/31	10.4	10.9	11.8	12.3	12.7	15.9	14.1	—	—	—	—
MH37	19.6	20.4	21.3	22.7	24.1	25.4	26.8	28.1	29.5	—	30.9
MH50/51	13.4	14.1	14.8	15.4	16.1	16.8	17.3	19.1	20.4	—	—
MH75/76	24.5	25.9	27.2	28.6	29.5	30.4	31.3	32.2	33.4	—	34.5
MH315	7.3	7.7	8.17	8.6	9.1	9.5	10	—	—	—	—
MH330	—	14.2	14.8	15.3	15.9	16.5	17	17.6	18.2	—	—
MH350	—	22.5	23.2	23.8	24.5	25.2	25.9	26.6	27.2	—	—
MH365	—	—	25.4	26.6	27.7	28.8	30	31.1	32.2	33.4	34.5

一台多联泵、马达的总重量等于单联泵、马达的重量加上额外增加的各联的重量。

注: 所有铸件重量仅供参考, 可能发生变化, 恕不通知。

产品系列及规格的识别

以下信息可以帮助您在现场识别一个泵或马达属于哪一系列和规格:

- 1 从后端盖看它与哪一种形式的产品最接近
- 2 测量后端盖的宽度，对照下表中符合哪个系列的产品

从后端盖看

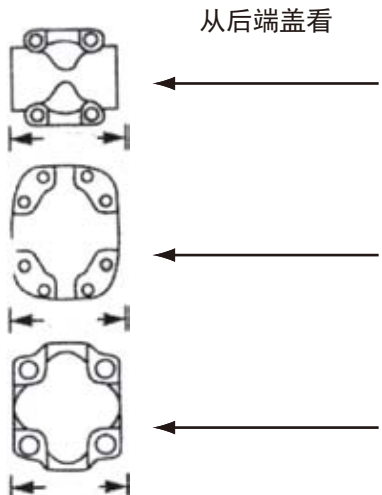

系列	MH315	MH330	MH350	MH365
测油口的宽度	108	170	181	187
无油口的宽度	102	122	146	159

系列	MH37X	MH75	MH76
宽度	130	156	156

系列	MH25	MH30/31	MH50/51
宽度	125	122	125

单位：英寸



规格	MH25, 30, 31, 50, 51							
齿轮壳体宽度	1.25	1.5	1.75	2	2.25	2.5	2.75	3
齿轮宽度	0.5	0.75	1	1.25	1.5	1.75	2	2.25

规格	MH37, 75, 76							
齿轮壳体宽度	1.5	1.75	2	2.25	2.5	2.75	3	4
齿轮宽度	0.5	0.75	1	1.25	1.5	1.75	2	3

规格	MH315							
齿轮壳体宽度	0.9	1.15	1.4	1.65	1.9	2.15	2.4	—
齿轮宽度	0.5	0.75	1	1.25	1.5	1.75	2	—

规格	MH330							
齿轮壳体宽度	1	1.5	1.75	2	2.25	2.5	—	—
齿轮宽度	0.5	1	1.25	1.5	1.75	2	—	—

规格	MH350							
齿轮壳体宽度	1	1.5	1.75	2	2.25	2.5	2.75	3
齿轮宽度	0.5	1	1.25	1.5	1.75	2	2.25	2.5

规格	MH365							
齿轮壳体宽度	1.5	1.75	2	2.25	2.5	2.75	3	—
齿轮宽度	1	1.25	1.5	1.75	2	2.25	2.5	—

- 4 从主轴看主轴的连接形式
- 5 确定油口位置和尺寸

MH25系列

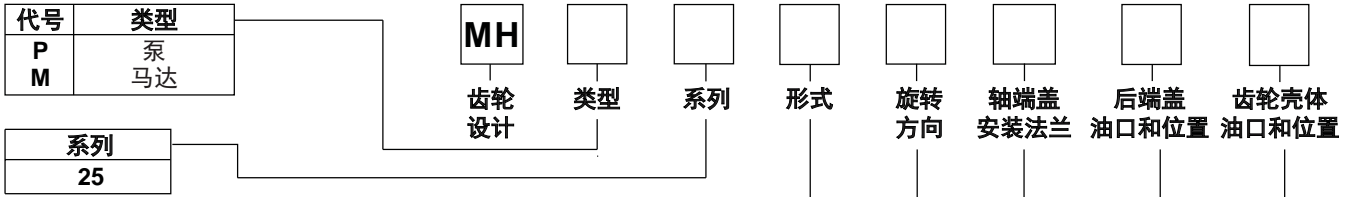

代号	形式
X	两件组合式轴的单联或多联泵

代号	旋转方向*
1	泵, 顺时针, 轴端有一个前置轴承 1型或2型
2	泵, 逆时针, 轴端有一个前置轴承 1型或2型
3	泵, 双向, 轴端有一个前置轴承 1型或2型
4	泵, 顺时针, 轴端有两个前置轴承 3型
5	泵, 逆时针, 轴端有两个前置轴承 3型
6	泵, 双向, 轴端有两个前置轴承 3型
7	马达, 轴端有一个前置轴承和1/4" BSP泄油口 1型或2型
8	马达, 轴端有两个前置轴承, 有1/4" BSP泄油口 3型
9	马达, 轴端有一个前置轴承, 无泄油口 1型或2型

代号	轴端盖 - 安装法兰
00	托板式安装法兰 1型或3型
01	改装型托板式安装法兰 1型
03	6螺栓圆形法兰 1型
04	4螺栓圆形法兰, 73.23mm止口 2型
05	6螺栓圆形法兰, 168.28mm止口 2型
07	4螺栓圆形法兰, 73.23mm止口 2型 (仅适用于58轴)
40	4螺栓方形法兰, 82.52mm止口 1型
42	SAE 4螺栓"B"型安装法兰 1型或3型
43	SAE 4螺栓"B"型安装法兰带两个泄油口 3型
78	SAE 4螺栓"C"型安装法兰 1型或3型
95	SAE 2螺栓"B"型安装法兰带两个泄油口 1型
97	SAE 2螺栓"B"型安装法兰 1型或3型
98	SAE 2螺栓"C"型安装法兰 1型

* 旋转方向* 定义: 面对轴端, 主轴在上, 顺时针时左侧为进油口, 右侧为出油口, 逆时针反之。

后端盖 - 油口规格和位置

无油口	单联泵	多联泵	带外伸螺栓
代号	BE	BI	BY

后油口 (泵)

油口		SAE O型圈密封油口			NPT 油口			BSP 油口		
左	右	单联泵	多联泵	带外伸螺栓	单联泵	多联泵	带外伸螺栓	单联泵	多联泵	带外伸螺栓
1/2"	-	HE	HI	HY	-	-	-	-	-	-
-	1/2"	DE	DI	DY	-	-	-	-	-	-
1/2"	1/2"	JE	JI	JY	-	-	-	-	-	-
5/8"	-	UE	UI	UY	-	-	-	-	-	-
-	5/8"	NE	NI	NY	-	-	-	-	-	-
3/4"	-	KE	KI	KY	FE	FI	FY	AE	AI	AY
-	3/4"	LE	LI	LY	CE	CI	CY	QE	QI	QY
3/4"	3/4"	ME	MI	MY	GE	GI	GY	SE	SI	SY

齿轮壳体 - 油口规格和位置: 详见MH25系列附表

Page 29

MH25系列

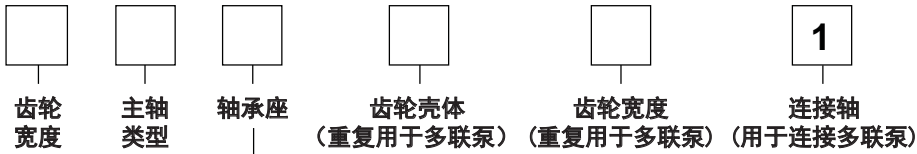

齿轮宽度				代号		主轴类型	
代号	齿轮宽度	排量 (cm ³ /rev)	最高压力 (bar)				
05	1/2"	20.9	175	03	6齿花键, 外径28.18mm, 轴伸53.98mm		1型
07	3/4"	31.3	175	07	SAE"C"型14齿花键, 外径31.75mm		1型
10	1"	41.8	175	11	SAE"C"型平键, 外径31.75mm		1型
12	1-1/4"	52.2	175	25	SAE"B"型13齿花键, 外径22.35mm		1型
15	1-1/2"	62.7	175	30	SAE"B"型平键, 外径22.35mm,		键6.35x9.53x25.4mm
17	1-3/4"	73.1	140	38	平键, 外径22.21mm, 轴伸36.51mm,		键31.75mm
20	2"	83.6	140	39	平键, 外径22.21mm, 轴伸74.61mm		1型
22	2-1/4"	94.0	140	43	SAE"BB"型平键, 外径25.4mm,		键6.35x9.53x31.75mm
25	2-1/2"	104.5	140	45	平键, 外径22.21mm, 轴伸61.12mm,		键31.75mm
				47	平键, 外径25.39mm,		键31.75mm
				48	SAE"B"型13齿花键, 外径22.23mm		2型
				53	SAE"C"型14齿花键, 外径31.75mm		2型
				61	平键, 外径31.75mm,		键38.1mm
				73	平键, 外径31.72mm		3型
				76	平键, 外径25.37mm, 带槽,		键38.1mm

轴承座 - 油口规格和形式

单出口 (泵)						单出口 (马达)				
油口		SAE O型圈密封油口		SAE美制拼合法兰油口		NPT油口		SAE O型圈密封油口		双向
进	出	顺时针	逆时针	顺时针	逆时针	顺时针	逆时针	进	出	
1-1/4"	1-1/4"							1"	1"	
1-1/2"	-	TH	-	FB	-	TL	-	1-1/4"	1-1/4"	
-	1-1/2"	-	TM	-	FT	-	TJ	1-1/2"	1-1/2"	
1-1/2"	1"				-		-	SAE型美制拼合法兰油口		双向
1"	1-1/2"	-	TN	-	XW	-	XT	进	出	
1"	3/4"							1"	1"	
公用吸油口 (泵)		顺时针	逆时针					1-1/4"	1-1/4"	
无油口								1-1/2"	1-1/2"	
无油口		A	U					NPT油口	双向	
								进	出	
								1"	1"	
								1-1/4"	1-1/4"	
								1-1/2"	1-1/2"	
								马达	双向	
								无油口		B

齿轮壳体 - 油口规格和形式

齿宽代码	25 系列							
	07	10	12	15	17	20	22	25
排量 (cc/rev)	31.3	41.8	52.3	62.8	73.1	83.6	94.0	104.5
最大工作压力 (bar)	175	175	175	175	140	140	140	140

进油口	出油口	顺时针	逆时针									
-	-	AB	AB	✓	✓	✓	✓	✓	✓	✓	✓	无油口

NPT油口

1/2"	-	AP	AC	✓								
-	1/2"	AC	AP	✓								
1/2"	1/2"	EC	EC	✓	✓							
3/4"	1/2"	EH	ED	✓								
3/4"	-	AR	AF	✓	✓	✓	✓	✓	✓			
-	3/4"	AF	AR	✓	✓	✓	✓	✓	✓			
3/4"	3/4"	ER	ER		✓	✓	✓	✓	✓	✓	✓	
1"	3/4"	IJ	ET		✓	✓	✓	✓	✓	✓	✓	
1-1/4"	3/4"	IQ	EU					✓	✓		✓	
1"	-	AT	AH		✓	✓	✓	✓	✓	✓	✓	
-	1"	AH	AT		✓	✓	✓	✓	✓	✓	✓	
1"	1"	IL	IL		✓	✓	✓	✓	✓	✓	✓	
1-1/4"*	1"	IS	IM				✓	✓	✓	✓	✓	
1-1/4"*	-	AV	AJ					✓	✓	✓	✓	
-	1-1/4"	AJ	AV					✓	✓	✓	✓	
1-1/4"	1-1/4"	IT	IT					✓	✓	✓	✓	
1-1/2"	1"	IY	-						✓	✓	✓	
1-1/2"*	1-1/4"	IZ	IU						✓	✓	✓	
1-1/2"	1-1/2"	JC	JC							✓	✓	
1-1/2"*	-	AW	AK						✓	✓	✓	
-	1-1/2"	AK	AW						✓	✓	✓	

BSPP油口

3/4"	-	EA	EM		✓	✓	✓					
-	3/4"	EM	EA		✓	✓	✓					
3/4"	3/4"	EJ	EJ		✓	✓	✓	✓	✓	✓		
1"	3/4"	EN	EK		✓	✓						
1-1/4"	3/4"	YW	YU		✓	✓	✓	✓				
1"	-	EP	IH				✓	✓	✓			
-	1"	IH	EP				✓	✓	✓			
1"	1"	EQ	EQ				✓	✓	✓	✓	✓	
1-1/4"*	1"	IR	ES				✓	✓	✓	✓	✓	
1-1/4"*	-	NJ	JB				✓	✓	✓		✓	
-	1-1/4"	JB	NJ				✓	✓	✓		✓	
1-1/4"	1-1/4"	IE	IE							✓		
1-1/2"	1"	ID	-							✓		
1-1/2"*	1-1/4"	IS	IQ								✓	
1-1/2"	1-1/2"	JV	JV								✓	

- 注：
- “*” 表示低压进油口
 - “✓” 表示推荐油口形式，其余的油口形式请咨询上海毅鸥公司
 - NPT油口建议用在压力低于103bar(1500psi)的情况下
 - 有阴影标注的油口规格可用于马达

MH25系列

齿轮壳体 - 油口规格和形式

齿宽代码	25 系列							
	07	10	12	15	17	20	22	25
排量 (cc/rev)	31.3	41.8	52.3	62.8	73.1	83.6	94.0	104.5
最大工作压力 (bar)	175	175	175	175	140	140	140	140

进油口	出油口	顺时针	逆时针						SAE美制拼合法兰油口
1/2"	-	OP	OC	✓					✓
-	1/2"	OC	OP	✓					✓
1/2"	1/2"	ZC	ZC						✓
3/4"	1/2"	ZP	ZF			✓	✓	✓	✓
3/4"	-	OR	OF			✓	✓	✓	✓
-	3/4"	OF	OR			✓	✓	✓	✓
3/4"	3/4"	ZR	ZR		✓	✓	✓	✓	✓
1"	3/4"	RJ	ZT		✓		✓	✓	✓
1-1/4"*	3/4"	RQ	ZU			✓	✓	✓	✓
1"	-	OT	OH		✓	✓	✓	✓	✓
-	1"	OH	OT		✓	✓	✓	✓	✓
1"	1"	RL	RL			✓	✓	✓	✓
1-1/4"*	1"	RS	RM			✓	✓	✓	✓
1-1/2"*	1"	RY	RN			✓	✓	✓	✓
2"	1"	OZ	OS					✓	✓
1-1/4"*	-	OV	OJ		✓	✓	✓	✓	✓
-	1-1/4"	OJ	OV		✓	✓	✓	✓	✓
1-1/4"	1-1/4"	RT	RT			✓	✓	✓	✓
1-1/2"*	1-1/4"	RZ	RU			✓	✓	✓	✓
2"*	1-1/4"	SG	RX					✓	✓
1-1/2"*	-	OW	OK			✓	✓	✓	✓
-	1-1/2"	OK	OW			✓	✓	✓	✓
1-1/2"	1-1/2"	SC	SC				✓	✓	✓
2"*	1-1/2"	SH	SD					✓	✓
2"*	-	OX	OL					✓	
-	2"	OL	OX						✓

SAE公制拼合法兰油口

1"	1"	ZQ	ZQ						✓
1-1/4"	1"	-	ZS			✓			
1-1/2"	1"	ZD	-						✓
1-1/4"	1-1/4"	ZE	ZE						✓
1-1/2"*	1-1/4"	RF	OA				✓	✓	
1-1/2"*	-	-	RW				✓		
-	1-1/2"	RW	-				✓		
1-1/2"	1-1/2"	RV	RV						✓
2"*	1-1/2"	-	RG						✓

- 注：
- “*”表示低压进油口
 - “✓”表示推荐油口形式，其余的油口形式请咨询上海毅鸥公司
 - 有阴影标注的油口规格可用于马达

齿轮壳体 - 油口规格和形式										
25 系列										
齿宽代码	07	10	12	15	17	20	22	25		
排量 (cc/rev)	31.3	41.8	52.3	62.8	73.1	83.6	94.0	104.5		
最大工作压力 (bar)	175	175	175	175	140	140	140	140		
进油口	出油口	顺时针	逆时针							SAE O型圈密封油口
1/2"	-	UP	UC	✓	✓	✓				
-	1/2"	UC	UP	✓	✓	✓				
1/2"	1/2"	YC	YC	✓	✓	✓	✓			
5/8"	1/2"	YJ	YD	✓	✓	✓				
5/8"	-	UQ	UD		✓	✓	✓			
-	5/8"	UD	UQ		✓	✓	✓			
5/8"	5/8"	YK	YK		✓	✓	✓	✓		
3/4"	5/8"	YQ	YL		✓	✓	✓	✓		
3/4"	-	UR	UF		✓	✓	✓	✓		
-	3/4"	UF	UR		✓	✓	✓	✓		
3/4"	3/4"	YR	YR		✓	✓	✓	✓	✓	
7/8"	3/4"	YX	YS					✓		
1"	3/4"	VJ	YT		✓					
7/8"	-	US	UG			✓	✓	✓	✓	
-	7/8"	UG	US			✓	✓	✓	✓	
7/8"	7/8"	YZ	YZ			✓	✓	✓	✓	
1"	7/8"	VK	VC			✓	✓	✓	✓	
1"	-	UT	UH			✓	✓	✓	✓	
-	1"	UH	UT			✓	✓	✓	✓	
1"	1"	VL	VL			✓	✓	✓	✓	
1-1/4"*	1"	VS	VM			✓	✓	✓	✓	
1-1/2"*	1"	VG	VN				✓			
1-1/4"	-	UV	UJ				✓	✓	✓	
-	1-1/4"	UJ	UV				✓	✓	✓	
1-1/4"	1-1/4"	VT	VT				✓	✓	✓	
1-1/2"	1-1/4"	VZ	VU				✓	✓	✓	
1-1/2"	-	UW	UK					✓		
-	1-1/2"	UK	UW					✓		
1-1/2"	1-1/2"	WC	WC						✓	

- 注：
- “*” 表示低压进油口
 - “✓” 表示推荐油口形式，其余的油口形式请咨询上海毅鸥公司
 - 有阴影标注的油口规格可用于马达

MH30/31系列

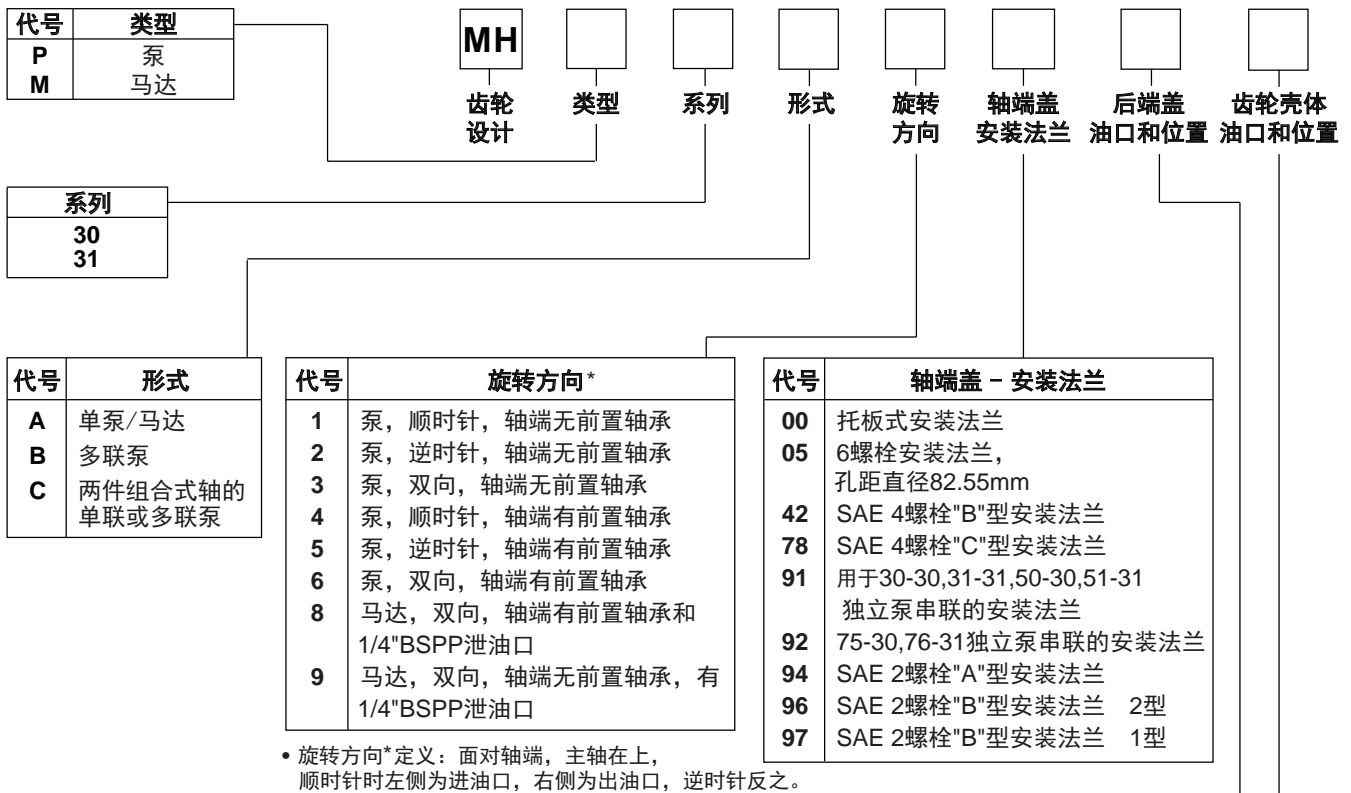

后端盖 - 油口规格和位置

无油口 代号	单联泵	多联泵	带外伸螺栓
	BE	BI	BY

后油口 (泵)

侧油口 (泵)

油口		SAE O型圈密封油口			NPT 油口			BSPP 油口			SAE O型圈密封油口		
		单联泵	多联泵	带外伸螺栓	单联泵	多联泵	带外伸螺栓	单联泵	多联泵	带外伸螺栓	单联泵	多联泵	带外伸螺栓
左	右												
1"	1"	-	-	-	-	-	-	-	-	-	-	-	-
3/4"	-	CA	CU	CO	KE	KI	KY	WE	WI	WY	-	-	-
-	3/4"	DA	DU	DO	LE	LI	LY	XE	XI	XY	-	-	-
3/4"	3/4"	JA	JU	BO	ME	MI	MY	ZE	ZI	ZY	-	-	-
1"	3/4"	KA	KU	-	-	-	-	-	-	-	-	-	-
3/4"	1"	LA	LU	-	-	-	-	-	-	-	-	-	-
1"	-	MA	MU	YO	-	-	-	-	-	-	-	-	-
-	1"	RA	SU	RO	-	-	-	-	-	-	-	-	-
1"	1"	ZA	ZU	ZO	-	-	-	-	-	-	-	-	-
1-1/4"	1"	GU	GU	-	-	-	-	-	-	-	TU	TU	-
1"	1-1/4"	HU	HU	-	-	-	-	-	-	-	XU	XU	-

齿轮壳体 - 油口规格和位置: MH30/31系列附表

MH30/31系列

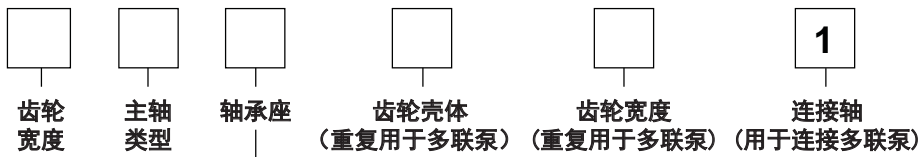

代号	齿轮宽度			
	齿轮宽度	排量 (cm³/rev)	最高压力(bar)	
			30系列	31系列
05	1/2"	16.1	175	210
07	3/4"	24.2	175	210
10	1"	32.3	175	210
12	1-1/4"	40.4	175	210
15	1-1/2"	48.4	175	210
17	1-3/4"	56.5	158	175
20	2"	64.6	158	175

代号	主轴类型
07	SAE“C”型14齿花键, 外径31.75mm
12	平键, 外径19.05mm, 键4.8x4.8x39.62mm
15	SAE“B”型平键, 外径22.23mm
25	SAE“B”型13齿花键, 外径22.35mm
30	SAE“B”型平键, 外径22.35mm, 键6.35x9.53x25.4mm
43	SAE“BB”型平键, 外径25.4mm, 键6.35x9.53x31.75mm
65	SAE“B”型13齿花键, 外径22.35mm 2型
66	SAE“B”型平键, 外径22.35mm, 键6.35x9.53x25.4mm 2型
67	SAE“BB”型平键, 外径25.4mm, 键6.35x9.53x31.75mm 2型
68	6齿花键, 外径25.4mm
95	SAE“A”型9齿花键, 外径15.75mm
98	SAE“BB”型15齿花键, 外径25.4mm

轴承座 - 油口规格和形式

单出口 (泵)												单出口 (马达)			
油口		SAE O型圈密封油口		BSPP油口		SAE美制拼合法兰油口		NPT油口		SAE公制拼合法兰油口		SAE O型圈密封油口	双向		
		顺时针	逆时针	顺时针	逆时针	顺时针	逆时针	顺时针	逆时针	顺时针	逆时针				
进	出											进	出		CC
1"	-	CB	BC	CX	XC	LB	BL	TB	BT	CH	HC	1"	1"		BB
1-1/4"	-	DB	BD	DX	XD	MB	BM	VB	BV	DH	HD	1-1/4"	1-1/4"		FF
1-1/2"	-	FB	BF	FX	XF	NB	BN	-	-	FH	HF	1-1/2"	1-1/2"		
-	3/4"	PJ	JP	-	TL	BR	RB	-	-	PW	WP	BSP油口		双向	
1"	3/4"	CJ	JC	CT	TC	LR	RL	TX	XT	CW	WC	进	出		EE
1-1/4"	3/4"	DJ	JD	DT	TD	MR	RM	VX	XV	DW	WD	1"	1"		GG
1-1/2"	3/4"	FJ	JF	FT	TF	NR	RN	-	-	FW	WF	SAE美制拼合法兰油口		双向	
1-1/4"	1"	DK	KD	DV	VD	MS	SM	VZ	ZV	DC	CD	进	出		LL
1-1/2"	1"	FK	KF	FV	VF	NS	SN	-	-	FC	CF	1"	1"		MM
1"	3/4"	CR	RC	GM	MG	LX	XL	TJ	JT	GQ	QG	1-1/4"	1-1/4"		NN
1-1/4"	3/4"	DR	RD	HM	MH	MX	XM	VJ	JV	HQ	QH	NPT油口		双向	
1-1/2"	3/4"	FR	RF	WM	MW	NX	XN	-	-	WQ	QW	进	出		TT
1-1/4"	1"	DS	SD	HN	NH	MZ	ZM	VK	KV	HS	SH	1"	1"		VV
1-1/2"	1"	FS	SF	WN	NW	NZ	ZN	KW	WK	WS	SW	1-1/4"	1-1/4"		
1"	3/4"	KJ	JK	PN	NP	SR	RS	ZX	XZ	ST	TS	SAE公制拼合法兰油口		双向	
1"	3/4"	KX	XK	SX	XS	RZ	ZR	ZS	SZ	PX	XP	进	出		RR
公用吸油口 (泵)		顺时针	逆时针												
无油口															
无油口		A	U												
		马达		双向											
无油口			B												

MH30/31系列

齿轮壳体 - 油口规格和形式																		
30 系列										31 系列								
齿宽代码	05	07	10	12	15	17	20	05	07	10	12	15	17	20				
排量 (cc/rev)	16.2	24.2	32.3	40.3	48.5	56.5	64.6	16.2	24.2	32.3	40.3	48.5	56.5	64.6				
最大工作压力 (bar)	175	175	175	175	175	158	158	210	210	210	210	210	175	175				
进油口	出油口	顺时针	逆时针											无油口				
-	-	AB	AB	✓	✓	✓	✓	✓	✓	✓	✓	✓	✓	✓	✓			
														NPT油口				
1/2"	-	IL	IM	✓	✓										✓	✓		
-	1/2"	IM	IL	✓	✓										✓	✓		
1/2"	1/2"	IR	IR	✓										✓	✓			
3/4"	-	IC	ID			✓	✓	✓	✓	✓	✓	✓	✓	✓	✓			
-	3/4"	ID	IC			✓	✓	✓	✓	✓	✓	✓	✓	✓	✓			
3/4"	3/4"	IF	IF			✓	✓	✓	✓	✓	✓	✓	✓	✓	✓			
1"*	3/4"	IJ	IG			✓*	✓	✓	✓	✓	✓	✓	✓	✓	✓			
1-1/4"*	3/4"	IK	IH												✓	✓		
1"*	-	YC	YD			✓*	✓	✓	✓					✓*	✓	✓		
-	1"	YD	YC			✓	✓	✓	✓					✓	✓	✓		
1"	1"	YF	YF								✓	✓	✓	✓	✓			
1-1/4"*	1"	YJ	YG								✓*	✓	✓	✓	✓			
1-1/4"*	-	IA	IB								✓*	✓	✓	✓	✓			
-	1-1/4"	IB	IA								✓*	✓	✓	✓	✓			
1-1/4"	1-1/4"	YL	YL												✓	✓		
1-1/2"*	-	YA	YB												✓*	✓*		
1-1/2"*	1-1/4"	YP	YM												✓*	✓*		
														SAE O型圈密封油口				
3/4"*	-	EC	ED			140	✓	✓	✓					✓*	✓	✓	✓	
-	3/4"	ED	EC			140	✓	✓	✓					✓*	✓	✓	✓	
3/4"	3/4"	EF	EF	✓*	140	✓	✓	✓	✓	✓*	✓	✓	✓	✓	✓			
1"*	3/4"	EJ	EG			140*	✓*	✓	✓	✓	✓	✓	✓	✓	✓			
1-1/4"*	3/4"	EK	EH								✓*	✓*	✓*	✓	✓			
1-1/2"*	3/4"	IP	IN								✓*	✓*			✓*			
7/8"	-	EZ	-												✓	✓		
-	7/8"	-	EZ												✓	✓		
1"*	7/8"	EM	EL	✓*	✓*					✓*	✓*				✓	✓		
1"*	-	AC	AD	✓*	140	✓	✓	✓	✓	✓*	✓*	175	✓	✓				
-	1"	AD	AC	✓*	140	✓	✓	✓	✓	✓*	✓*	175	✓	✓				
1"	1"	AF	AF			✓*	✓	✓	✓					✓*	175	✓	✓	
1-1/4"*	1"	AJ	AG								✓*	✓*	✓	175*	✓*	✓*		
1-1/2"*	1"	AK	AH								✓*	✓*				✓*	✓*	
1-1/4"*	-	AA	AO								✓*	140				✓*	✓*	
-	1-1/4"	AO	AA												140	✓*	✓*	
1-1/4"	1-1/4"	AL	AL												140	✓	✓	
1-1/2"*	1-1/4"	AP	AM												140*	✓*	✓*	
1-1/2"*	-	AE	AU												✓*	140	✓*	✓*
-	1-1/2"	AU	AE												✓*	140	✓*	✓*

注： • “*” 表示低压进油口
 • “✓” 表示推荐油口形式，其余的油口形式请咨询上海毅鸥公司
 • NPT油口建议用在压力低于103bar(1500psi)的情况下
 • 有阴影标注的油口规格可用于马达
 • “140”或“175”表示油口最高工作压力为140bar或者175bar

MH30/31系列

齿轮壳体 - 油口规格和形式																
齿宽代码	30 系列								31 系列							
	05	07	10	12	15	17	20	05	07	10	12	15	17	20		
排量 (cc/rev)	16.2	24.2	32.3	40.3	48.5	56.5	64.6	16.2	24.2	32.3	40.3	48.5	56.5	64.6		
最大工作压力 (bar)	175	175	175	175	175	158	158	210	210	210	210	210	175	175		
进油口	出油口	顺时针	逆时针	SAE美制拼合法兰油口												
3/4"	-	UC	UD		✓	✓	✓	✓			✓	✓	✓	✓		
-	3/4"	UD	UC		✓	✓	✓	✓			✓	✓	✓	✓		
3/4"	3/4"	UF	UF	✓	✓	✓	✓	✓	✓	✓	✓	✓	✓	✓		
1"	3/4"	UJ	UG		✓	✓	✓	✓	✓	✓*	✓	✓	✓	✓		
1-1/4"	3/4"	UK	UH			✓	✓	✓	✓		✓*	✓*	✓	✓		
1"	-	OC	OD			✓	✓	✓	✓		175	✓	✓	✓		
-	1"	OD	OC			✓	✓	✓	✓		175	✓	✓	✓		
1"	1"	OF	OF		✓	✓	✓	✓	✓		175	✓	✓	✓		
1-1/4"	1"	OJ	OG			✓*	✓	✓	✓			✓*	✓*	✓		
1-1/2"	1"	OK	OH					✓*	✓				✓*	✓*		
1-1/4"	-	OA	OB			140	✓	✓	✓			✓*	175	✓		
-	1-1/4"	OB	OA			140	✓	✓	✓			✓*	175	✓		
1-1/4"	1-1/4"	OL	OL				✓	✓	✓				✓	✓		
1-1/2"	1-1/4"	OP	OM					✓*	✓				✓*	✓*		
1-1/2"	-	OE	OU						140	✓			✓*	✓		
-	1-1/2"	OU	OE						140	✓			✓*	✓		
BSPP油口																
3/4"	-	YN	YQ		✓*	✓	✓	✓	✓	✓		175	✓	✓		
-	3/4"	YQ	YN		✓*	✓	✓	✓	✓	✓		175	✓	✓		
3/4"	3/4"	YS	YS			✓	✓	✓	✓	✓		175	✓	✓		
1"	3/4"	YV	YT			✓*	✓*	✓	✓			175*	✓*	✓*		
1-1/4"	3/4"	YW	YU						✓*	✓*			✓*	✓*		
1"	-	SL	RQ				140	✓	✓	✓		✓		175		
-	1"	RQ	SL				140	✓	✓	✓				175		
1"	1"	MP	MP			✓*	140	✓	✓	✓				✓		
1-1/4"	1"	IX	VY					✓*	✓*	✓*				175*		
1-1/4"	-	NJ	UI						140	✓*				✓*		
-	1-1/4"	UI	NJ						140	✓*				✓*		
1-1/4"	1-1/4"	PF	PF					✓*	140	✓				✓		
SAE公制拼合法兰油口																
3/4"	-	VN	VQ			✓	✓	✓	✓			✓	✓	✓		
-	3/4"	VQ	VN			✓	✓	✓	✓			✓	✓	✓		
3/4"	3/4"	VS	VS				✓	✓	✓	✓		✓		✓		
1"	3/4"	RV	VT			✓	✓	✓	✓			✓*	✓			
1-1/4"	3/4"	RW	RU				✓*	✓	✓				✓*	✓*		
1"	-	UL	UR			✓	✓	✓	✓	✓		175	✓	✓		
-	1"	UR	UL			✓	✓	✓	✓	✓		175	✓	✓		
1"	1"	UM	UM			✓	✓	✓	✓	✓			✓	✓		
1-1/4"	1"	UX	VU				✓*	✓	✓	✓			✓*	✓*		
1-1/2"	1"	VO	HO						✓*	✓				✓*		
1-1/4"	-	NO	UO				✓	✓	✓	✓			✓*	175		
-	1-1/4"	UO	NO				✓	✓	✓	✓			✓*	175		
1-1/4"	1-1/4"	PO	PO					✓	✓	✓				✓		
1-1/2"	1-1/4"	SO	QO						✓*	✓			✓*	✓*		
1-1/2"	-	UY	TO							140	✓		✓*	✓		
-	1-1/2"	TO	UY							140	✓		✓*	✓		

注: •“*”表示低压进油口

•有阴影标注的油口规格可用于马达

•“✓”表示推荐油口形式,其余的油口形式请咨询上海毅鸥公司

•“140”或“175”表示油口最高工作压力为140bar或者175bar

MH37系列



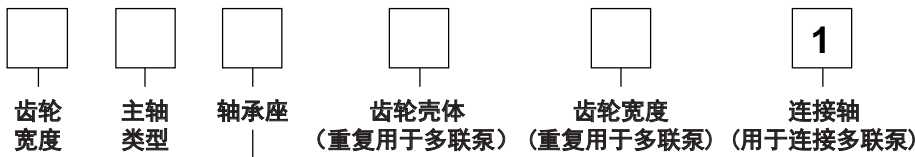

代号	齿轮宽度			代号	主轴类型
	齿轮宽度	排量 (cm ³ /rev)	最高压力 (bar)		
07	3/4"	36.9	140	02	平键, 外径28.57mm
10	1"	49.2	140	03	6齿花键, 外径28.18mm, 轴伸53.98mm
12	1-1/4"	61.4	140	06	6齿花键, 外径24.54mm
15	1-1/2"	73.7	140	07	SAE“C”型14齿花键, 外径31.75mm
17	1-3/4"	86.2	140	08	平键, 外径31.75mm 1型
20	2"	98.3	140	10	6齿花键, 外径28.54mm
22	2-1/4"	110.6	140	11	SAE“C”型平键, 外径31.75mm
25	2-1/2"	122.9	140	25	SAE“B”型13齿花键, 外径22.35mm
30	3"	147.5	140	30	SAE“B”型平键, 外径22.35mm, 键6.35x9.53x25.4mm
				38	平键, 外径22.21mm, 轴伸36.51mm, 键31.75mm
				73	平键, 外径31.72mm

轴承座 - 油口规格和形式

单出口 (泵)						单出口 (马达)				
油口		SAE O型圈密封油口		SAE美制拼合法兰油口		NPT油口		SAE O型圈密封油口	双向	
进	出	顺时针	逆时针	顺时针	逆时针	顺时针	逆时针	进	出	
1-1/4"	1-1/4"							1"	1"	CC
1-1/2"	-	NG	-	FB	-	TL	-	1-1/4"	1-1/4"	BB
-	1-1/2"	-	NK	-	FT	-	TJ	1-1/2"	1-1/2"	FF
1-1/2"	1"		-		-		-	SAE型美制拼合法兰油口		双向
1"	1-1/2"	-	XZ	-	XW	-	XT	进	出	
1"	1"							1"	1"	LL
								1-1/4"	1-1/4"	MM
								1-1/2"	1-1/2"	NN
公用吸油口 (泵)		顺时针	逆时针	NPT油口		双向		进	出	
无油口				进	出	1"	1"	1"	1"	TT
无油口		A	U	1-1/4"	1-1/4"	1-1/4"	1-1/4"	1-1/2"	1-1/2"	VV
				1-1/2"	1-1/2"	1-1/2"	1-1/2"			WW
				马达		双向		无油口		B

MH37系列

齿轮壳体 - 油口规格和形式

37 系列

齿宽代码	07	10	12	15	17	20	22	25	30
排量 (cc/rev)	36.9	49.2	61.4	73.7	86.2	98.3	110.6	122.9	147.5
最大工作压力 (bar)	140	140	140	140	140	140	140	140	140

进油口	出油口	顺时针	逆时针
-----	-----	-----	-----

无油口

-	-	AB	AB	✓	✓	✓	✓	✓	✓	✓	✓	✓
---	---	----	----	---	---	---	---	---	---	---	---	---

NPT油口

1/2"	1/2"	EC	EC	✓	✓	✓						
3/4"	-	AR	AF	✓	✓	✓	✓	✓				
-	3/4"	AF	AR	✓	✓	✓	✓	✓				
3/4"	3/4"	ER	ER	✓	✓	✓	✓	✓	✓	✓	✓	✓
1"	3/4"	IJ	ET		✓	✓	✓	✓	✓	✓	✓	✓
1-1/4"	3/4"	IQ	EU			✓	✓	✓	✓	✓	✓	✓
1"	-	AT	AH		✓	✓	✓	✓	✓	✓	✓	✓
-	1"	AH	AT		✓	✓	✓	✓	✓	✓	✓	✓
1"	1"	IL	IL		✓	✓	✓	✓	✓	✓	✓	✓
1-1/4"*	1"	IS	IM			✓	✓	✓	✓	✓	✓	✓
1-1/2"	1"	IY	IN					✓	✓	✓	✓	✓
1-1/4"*	-	AV	AJ			✓	✓	✓	✓	✓	✓	✓
-	1-1/4"	AJ	AV			✓	✓	✓	✓	✓	✓	✓
1-1/4"	1-1/4"	IT	IT			✓	✓	✓	✓	✓	✓	✓
1-1/2"*	1-1/4"	IZ	IU					✓	✓	✓	✓	✓
1-1/2"	1-1/2"	JC	JC					✓	✓	✓	✓	✓
1-1/2"*	-	AW	AK					✓	✓	✓	✓	✓
-	1-1/2"	AK	AW					✓	✓	✓	✓	✓

BSPP油口

3/4"	-	EA	EM		✓	✓	✓					
-	3/4"	EM	EA		✓	✓	✓					
3/4"	3/4"	EJ	EJ		✓	✓	✓	✓				
1"	3/4"	EN	EK		✓	✓						
1-1/4"	3/4"	YW	YU		✓	✓	✓	✓				
1"	-	EP	IH				✓	✓	✓			
-	1"	IH	EP				✓	✓	✓			
1"	1"	EQ	EQ				✓	✓	✓			
1-1/4"*	1"	IR	ES				✓	✓	✓			
1-1/2"	1"	ID	-							✓		
1-1/4"*	-	NJ	JB			✓	✓	✓	✓			
-	1-1/4"	JB	NJ			✓	✓	✓	✓			
1-1/4"	1-1/4"	IE	IE						✓			
1-1/2"*	1-1/4"	IS	IQ							✓	✓	
1-1/2"	1-1/2"	JV	JV							✓	✓	

- 注：
- “*” 表示低压进油口
 - “✓” 表示推荐油口形式，其余的油口形式请咨询上海毅鸥公司
 - NPT油口建议用在压力低于103bar(1500psi)的情况下
 - 有阴影标注的油口规格可用于马达

齿轮壳体 - 油口规格和形式											
37 系列											
齿宽代码	07	10	12	15	17	20	22	25	30		
排量 (cc/rev)	36.9	49.2	61.4	73.7	86.2	98.3	110.6	122.9	147.5		
最大工作压力 (bar)	140	140	140	140	140	140	140	140	140		
进油口	出油口	顺时针	逆时针								SAE O型圈密封油口
1/2"	-	UP	UC	✓	✓	✓	✓				
-	1/2"	UC	UP	✓	✓	✓	✓				
1/2"	1/2"	YC	YC	✓	✓	✓	✓				
5/8"	1/2"	YJ	YD	✓	✓	✓	✓				
5/8"	-	UQ	UD	✓	✓	✓	✓				
-	5/8"	UD	UQ	✓	✓	✓	✓				
5/8"	5/8"	YK	YK	✓	✓	✓	✓				
3/4"	5/8"	YQ	YL		✓	✓	✓	✓	✓		
3/4"	-	UR	UF		✓	✓	✓	✓	✓		
-	3/4"	UF	UR		✓	✓	✓	✓	✓		
3/4"	3/4"	YR	YR		✓	✓	✓	✓	✓		
7/8"	3/4"	YX	YS			✓	✓	✓	✓		
1"	3/4"	VJ	YT		✓	✓	✓	✓	✓		
7/8"	-	US	UG			✓	✓	✓	✓		
-	7/8"	UG	US			✓	✓	✓	✓		
7/8"	7/8"	YZ	YZ			✓	✓	✓	✓		
1"	7/8"	VK	VC			✓	✓	✓	✓		
1"	-	UT	UH			✓	✓	✓	✓		
-	1"	UH	UT			✓	✓	✓	✓		
1"	1"	VL	VL			✓	✓	✓	✓		
1-1/4"	1"	VS	VM				✓	✓	✓	✓	
1-1/4"	-	UV	UJ				✓	✓	✓		
-	1-1/4"	UJ	UV				✓	✓	✓		
1-1/4"	1-1/4"	VT	VT				✓	✓	✓	✓	
1-1/2"	1-1/4"	VZ	VU				✓	✓	✓	✓	
1-1/2"	-	UW	UK					✓	✓		
-	1-1/2"	UK	UW					✓	✓		
1-1/2"	1-1/2"	WC	WC					✓	✓		

- 注：
- “*” 表示低压进油口
 - “✓” 表示推荐油口形式，其余的油口形式请咨询上海毅鸥公司
 - 有阴影标注的油口规格可用于马达

MH37系列

齿轮壳体 - 油口规格和形式													
37 系列													
齿宽代码	07	10	12	15	17	20	22	25	30				
排量 (cc/rev)	36.9	49.2	61.4	73.7	86.2	98.3	110.6	122.9	147.5				
最大工作压力 (bar)	140	140	140	140	140	140	140	140	140				
进油口	出油口	顺时针	逆时针										SAE美制拼合法兰油口
1/2"	-	OP	OC	✓	✓	✓	✓						
-	1/2"	OC	OP	✓	✓	✓	✓						
1/2"	1/2"	ZC	ZC		✓	✓	✓						
3/4"	1/2"	ZP	ZF	✓	✓	✓	✓						
3/4"	-	OR	OF		✓	✓	✓	✓	✓	✓	✓	✓	
-	3/4"	OF	OR		✓	✓	✓	✓	✓	✓	✓	✓	
3/4"	3/4"	ZR	ZR		✓	✓	✓	✓	✓	✓	✓	✓	
1"	3/4"	RJ	ZT		✓	✓	✓	✓	✓	✓	✓	✓	
1-1/4"	3/4"	RQ	ZU			✓	✓	✓	✓	✓	✓	✓	
1"	-	OT	OH		✓	✓	✓	✓	✓	✓	✓	✓	
-	1"	OH	OT		✓	✓	✓	✓	✓	✓	✓	✓	
1"	1"	RL	RL			✓	✓	✓	✓	✓	✓	✓	
1-1/4"	1"	RS	RM			✓	✓	✓	✓	✓	✓	✓	
1-1/2"	1"	RY	RN			✓	✓	✓	✓	✓	✓	✓	
1-1/4"	-	OV	OJ			✓	✓	✓	✓	✓	✓	✓	
-	1-1/4"	OJ	OV			✓	✓	✓	✓	✓	✓	✓	
1-1/4"	1-1/4"	RT	RT				✓	✓	✓	✓	✓	✓	
1-1/2"	1-1/4"	RZ	RU				✓	✓	✓	✓	✓	✓	
2"	1-1/4"	SG	RX							✓	✓	✓	
1-1/2"	-	OW	OK				✓	✓	✓	✓	✓	✓	
-	1-1/2"	OK	OW				✓	✓	✓	✓	✓	✓	
1-1/2"	1-1/2"	SC	SC				✓	✓	✓	✓	✓	✓	
2"	1-1/2"	SH	SD					✓	✓	✓	✓	✓	
2-1/2"	1-1/2"	SN	SF						✓	✓	✓	✓	
2"	-	OX	OL							✓	✓	✓	
-	2"	OL	OX							✓	✓	✓	
2"	2"	SK	SK								✓	✓	
2-1/2"	-	OY	OM									✓	
-	2-1/2"	OM	OY									✓	
2-1/2"	2-1/2"	SQ	SQ									✓	

- 注：
- “*” 表示低压进油口
 - “✓” 表示推荐油口形式，其余的油口形式请咨询上海毅鸥公司
 - 有阴影标注的油口规格可用于马达

MH50/51系列

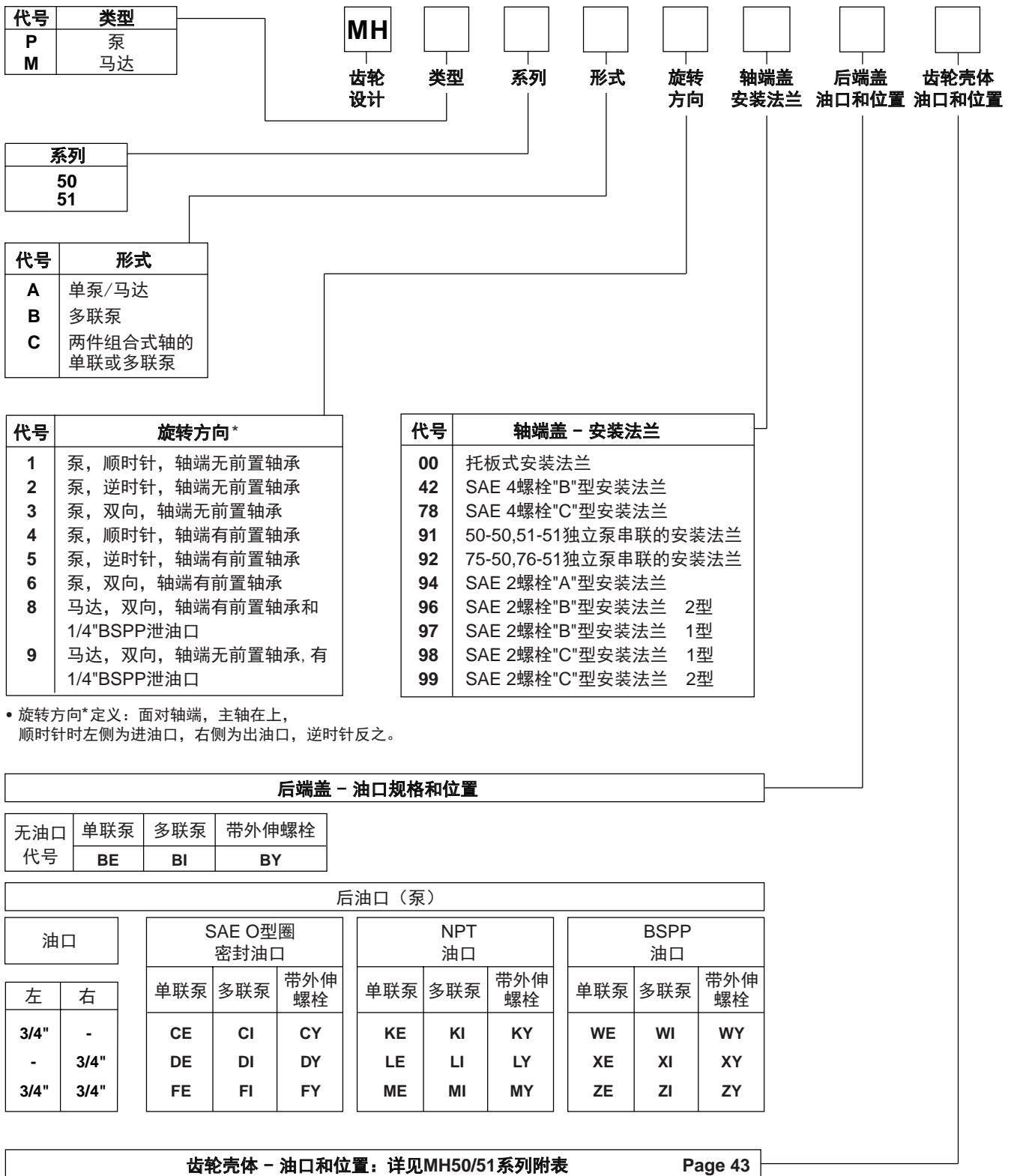

MH50/51系列

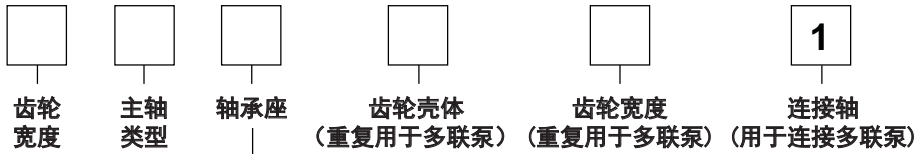

代号	齿轮宽度			
	齿轮宽度	排量 (cm ³ /rev)	最高压力(bar)	
			50系列	51系列
05	1/2"	20.9	175	210
07	3/4"	31.3	175	210
10	1"	41.8	175	210
12	1-1/4"	52.3	175	210
15	1-1/2"	62.8	175	210
17	1-3/4"	73.1	140	210
20	2"	83.6	140	175
22	2-1/4"	94.0	140	175
25	2-1/2"	104.5	140	175

代号	主轴类型
07	SAE“C”型14齿花键, 外径31.75mm 1型
11	SAE“C”型平键, 外径31.75mm, 键7.94x11.91x38.1mm
25	SAE“B”型13齿花键, 外径22.35mm
43	SAE“BB”型平键, 外径25.4mm, 键6.35x9.53x31.75mm 1型
53	SAE“C”型14齿花键, 外径31.75mm 2型
65	SAE“B”型13齿花键, 外径22.35mm 2型
67	SAE“BB”型平键, 外径25.4mm, 键6.35x9.53x31.75mm 2型
73	SAE“C”型平键, 外径31.75mm, 键7.94x11.91x57.15mm
98	SAE“BB”型15齿花键, 外径25.4mm

轴承座 - 油口规格和形式

单出口 (泵)												单出口 (马达)		
油口		SAE O型圈密封油口		BSPP油口		SAE美制拼合法兰油口		NPT油口		SAE公制拼合法兰油口		SAE O型圈密封油口	双向	
		顺时针	逆时针	顺时针	逆时针	顺时针	逆时针	顺时针	逆时针	顺时针	逆时针	进	出	
进	出													
1"	-	CB	BC	CX	XC	LB	BL	TB	BT	CH	HC	1"	1"	CC
1-1/4"	-	DB	BD	DX	XD	MB	BM	VB	BV	DH	HD	1-1/4"	1-1/4"	BB
1-1/2"	-	FB	BF	FX	XF	NB	BN	WB	BW	FH	HF	1-1/2"	1-1/2"	FF
												BSPP油口		双向
												进	出	
-	3/4"	PJ	JP	-	TL	BR	RB	-	-	PW	WP	1"	1"	EE
1"	3/4"	CJ	JC	CT	TC	LR	RL	TX	XT	CW	WC	1-1/4"	1-1/4"	GG
1-1/4"	3/4"	DJ	JD	DT	TD	MR	RM	VX	XV	DW	WD	SAE型美制拼合法兰油口		双向
1-1/2"	3/4"	FJ	JF	FT	TF	NR	RN	WX	XW	FW	WF	进	出	
1-1/4"	1"	DK	KD	DV	VD	MS	SM	VZ	ZV	DC	CD	1"	1"	LL
1-1/2"	1"	FK	KF	FV	VF	NS	SN	WZ	ZW	FC	CF	1-1/4"	1-1/4"	MM
												1-1/2"	1-1/2"	NN
1"	3/4"	CR	RC	GM	MG	LX	XL	TJ	JT	GQ	QG	NPT油口		双向
1-1/4"	3/4"	DR	RD	HM	MH	MX	XM	VJ	JV	HQ	QH	进	出	
1-1/2"	3/4"	FR	RF	WM	MW	-	-	-	-	WQ	QW	1"	1"	TT
1-1/4"	1"	DS	SD	HN	NH	MZ	ZM	VK	KV	HS	SH	1-1/4"	1-1/4"	VV
1-1/2"	1"	FS	SF	WN	NW	NZ	ZN	WK	KW	WS	SW	1-1/2"	1-1/2"	WW
-	1"	HZ	ZH	-	-	-	-	-	-	-	-	SAE型公制拼合法兰油口		双向
1"	3/4"	KJ	JK	PN	NP	SR	RS	ZX	XZ	ST	TS	进	出	
公用吸油口 (泵)		顺时针	逆时针									1"	1"	RR
无油口		C	D									1-1/4"	1-1/4"	SS
无油口		A	U									马达		双向
												无油口		B

齿轮壳体 - 油口规格和形式																		
50 系列										51 系列								
齿宽代码	07	10	12	15	17	20	22	25		07	10	12	15	17	20	22	25	
排量 (cc/rev)	31.3	41.8	52.3	62.8	73.1	83.6	94.0	104.5		31.3	41.8	52.3	62.8	73.1	83.6	94.0	104.5	
最大工作压力 (bar)	175	175	175	175	140	140	140	140		210	210	210	210	210	175	175	175	
进油口	出油口	顺时针	逆时针															
-	-	AB	AB	✓	✓	✓	✓	✓	✓	✓	✓	✓	✓	✓	✓	✓	✓	无油口
NPT油口																		
3/4"	-	IC	ID	✓	✓	✓	✓			✓	✓	✓	✓					
-	3/4"	ID	IC	✓	✓	✓	✓			✓	✓	✓	✓					
3/4"	3/4"	IF	IF	✓	✓	✓	✓	✓		✓	✓	✓	✓	✓				
1"*	3/4"	IJ	IG	✓*	✓	✓	✓	✓		✓*	✓	✓	✓	✓				
1-1/4"	3/4"	IK	IH			✓	✓	✓				✓	✓	✓				
1"	-	YC	YD		✓	✓	✓	✓	✓		✓	✓	✓	✓	✓	✓		
-	1"	YD	YC		✓	✓	✓	✓	✓		✓	✓	✓	✓	✓	✓		
1"	1"	YF	YF		✓	✓	✓	✓	✓		✓	✓	✓	✓	✓	✓	✓	
1-1/4"*	1"	YJ	YG			✓*	✓	✓	✓			✓*	✓	✓	✓	✓	✓	
1-1/4"*	-	IA	IB			✓*	✓*	✓	✓			✓*	✓*	✓	✓	✓	✓	
-	1-1/4"	IB	IA			✓*	✓*	✓	✓			✓*	✓*	✓	✓	✓	✓	
1-1/4"	1-1/4"	YL	YL				✓	✓	✓				✓	✓	✓	✓		
1-1/2"	1"	YK	YH				✓	✓	✓									
1-1/2"*	1-1/4"	YP	YM				✓*	✓	✓					✓*	✓	✓		
1-1/2"	-	YA	YB						✓									
-	1-1/2"	YB	YA						✓									
1-1/2"*	1-1/2"	YR	YR					✓	✓						✓	✓	✓	
SAE美制拼合法兰油口																		
3/4"	-	UC	UD	✓	✓	✓	✓			175	✓	✓	✓					
-	3/4"	UD	UC	✓	✓	✓	✓			175	✓	✓	✓					
3/4"	3/4"	UF	UF	✓	✓	✓	✓	✓	✓	175	✓	✓	✓	✓	✓	✓	✓	
1"*	3/4"	UJ	UG	✓*	✓*	✓	✓	✓		175*	✓*	✓*	✓	✓				
1-1/4"*	3/4"	UK	UH		✓						✓*	✓*	✓*					
1"*	-	OC	OD	140	✓*	✓	✓	✓	✓	✓*	✓*	175	✓	✓	✓	✓	✓	
-	1"	OD	OC	140	140	✓	✓	✓	✓	✓*	✓*	175	✓	✓	✓	✓	✓	
1"	1"	OF	OF	✓*	140	✓	✓	✓	✓	✓*	175	✓	✓	✓	✓	✓	✓	
1-1/4"*	1"	OJ	OG		140*	✓*	✓*	✓	✓	✓*	175*	✓*	✓*	✓	✓	✓	✓	
1-1/2"*	1"	OK	OH			✓*	✓*	✓*	✓			175*	✓*	✓*	✓	✓	✓	
1-1/4"*	-	OA	OB		✓*	✓*	✓*	✓	✓	✓*	✓*	✓*	✓	✓	✓	✓	✓	
-	1-1/4"	OB	OA		✓*	✓*	✓*	✓	✓	✓*	✓*	✓*	✓	✓	✓	✓	✓	
1-1/4"	1-1/4"	OL	OL			140	✓	✓	✓			✓*	✓	✓	✓	✓	✓	
1-1/2"*	1-1/4"	OP	OM			140	✓*	✓*	✓	✓*	✓*	✓*	✓*	✓	✓	✓	✓	
1-1/2"*	-	OE	OU			✓*	✓*	✓	✓			✓*	✓*	✓*	✓	✓	✓	
-	1-1/2"	OU	OE			✓*	✓*	✓	✓			✓*	✓*	✓*	✓	✓	✓	
1-1/2"	1-1/2"	OR	OR			✓	✓	✓	✓			✓	✓	✓	✓	✓	✓	
2"*	-	XB	ZB															✓
2"*	1"	UQ	UB					✓*	✓*	✓*					✓*	✓*	✓*	
2"*	1-1/4"	OQ	ON				✓*	✓*	✓*						✓*	✓*	✓*	
2"*	1-1/2"	OV	OS				✓*	✓*	✓*						✓*	✓*	✓*	
2"	2"	OX	OX						✓*									✓*

注： • “*”表示低压进油口
 • “✓”表示推荐油口形式，其余的油口形式请咨询上海毅鸥公司
 • NPT油口建议用在压力低于103bar(1500psi)的情况下
 • 有阴影标注的油口规格可用于马达
 • “140”或“175”表示油口最高工作压力为140bar或者175bar

MH50/51系列

齿轮壳体 - 油口规格和形式																	
50 系列										51 系列							
齿宽代码	07	10	12	15	17	20	22	25		07	10	12	15	17	20	22	25
排量 (cc/rev)	31.3	41.8	52.3	62.8	73.1	83.6	94.0	104.5		31.3	41.8	52.3	62.8	73.1	83.6	94.0	104.5
最大工作压力 (bar)	175	175	175	175	140	140	140	140		210	210	210	210	210	175	175	175
进油口	出油口	顺时针	逆时针														
SAE O型圈密封油口																	
3/4"*	-	EC	ED	140	140	✓	✓	✓			✓*	✓*	✓	✓	✓	✓	✓
-	3/4"	ED	EC	140	140	✓	✓	✓			✓*	✓*	✓	✓	✓	✓	✓
3/4"	3/4"	EF	EF	140	140	✓	✓	✓			✓*	✓*	175	✓	✓	✓	✓
1"*	3/4"	EJ	EG	140*	140*	✓*	✓*	✓	✓	✓	✓*	✓*	✓*	✓*			
1-1/4"*	3/4"	EK	EH			✓*	✓*						175*	✓*			
1"*	-	AC	AD	✓*	✓*	140	✓	✓	✓	✓	✓*	✓*	✓*	✓*	✓	✓	✓
-	1"	AD	AC	✓*	✓*	140	✓	✓	✓	✓	✓*	✓*	✓*	✓*	✓	✓	✓
1"	1"	AF	AF			140	✓	✓	✓	✓			✓*	✓	✓	✓	✓
1-1/4"*	1"	AJ	AG			140*	✓*	✓*	✓	✓			✓*	✓*	✓*	✓	✓
1-1/2"*	1"	AK	AH				✓*	✓*	✓*	✓*				✓*	✓*	✓	✓
1-1/4"*	-	AA	AO			✓*	✓*	✓*	✓	✓			✓*	✓*	✓	✓	✓
-	1-1/4"	AO	AA			✓*	✓*	✓*	✓	✓			✓*	✓*	✓	✓	✓
1-1/4"	1-1/4"	AL	AL				✓	✓	✓				✓*	✓*	✓	✓	✓
1-1/2"*	1-1/4"	AP	AM				✓*	✓*	✓						✓*	✓	✓
1-1/2"*	-	AE	AU				✓*	✓*	✓						✓*	✓	✓
-	1-1/2"	AU	AE				✓*	✓	✓						✓*	✓	✓
1-1/2"	1-1/2"	AR	AR						✓							✓	✓
BSPP油口																	
3/4"*	-	YN	YQ	✓*	✓	✓	✓				✓*	175	175	✓			
-	3/4"	YQ	YN		✓	✓	✓					175	175	✓			
3/4"	3/4"	YS	YS		✓	✓		✓				175	175				
1"*	3/4"	YV	YT		✓*	✓*						175*	175*				
1-1/4"*	3/4"	YW	YU			✓*											
1"*	-	SL	RQ		✓*	✓*	✓*	✓	✓	✓	✓*	✓*	✓*	✓*	✓*	✓	✓
-	1"	RQ	SL				✓	✓	✓						175	✓	✓
1"	1"	MP	MP			140	✓	✓	✓						175		✓
1-1/4"*	1"	IX	VY			140*	✓*	✓*	✓	✓					175*	✓	✓
1-1/2"*	1"	VI	HW												✓*		✓*
1-1/4"*	-	NJ	UI				✓*		✓	✓							✓
-	1-1/4"	UI	NJ						✓	✓							✓
1-1/4"	1-1/4"	PF	PF						✓	✓							✓
1-1/2"*	1-1/4"	IS	IQ						✓								✓*
SAE公制拼合法兰油口																	
3/4"*	-	VN	VQ	✓	✓	✓	✓				✓*						
-	3/4"	VQ	VN	✓	✓	✓	✓										
1"*	3/4"	RV	VT	✓*	✓*	✓	✓	✓			175*	✓*					
1-1/4"*	3/4"	RW	RU									✓*	✓*				
1"*	-	UL	UR		✓*	✓	✓	✓	✓			✓*	✓*	✓	✓		
-	1"	UR	UL			✓	✓	✓	✓					✓	✓		
1"	1"	UM	UM			140	✓	✓	✓	✓			175	✓	✓	✓	
1-1/4"*	1"	UX	VU			140*	✓*	✓*	✓	✓			175*	✓*	✓*		
1-1/2"*	1"	VO	HO				✓*	✓*	✓*				175*	✓*	✓*	✓	
1-1/4"*	-	NO	UO				✓*	✓	✓	✓			✓*	✓*			
-	1-1/4"	UO	NO					✓	✓	✓							
1-1/4"	1-1/4"	PO	PO			140	✓	✓	✓	✓							✓
1-1/2"*	1-1/4"	SO	QO			140*	✓*	✓*	✓	✓			✓*	✓*	✓*	✓	✓
1-1/2"*	-	UY	TO				✓*	✓*	✓					✓*	✓*		
-	1-1/2"	TO	UY						✓								
1-1/2"	1-1/2"	SV	SV				✓	✓	✓								✓
2"*	1-1/4"	JM	JR				✓*	✓*	✓*								✓*
2"*	1-1/2"	JQ	JN				✓*	✓*	✓*								✓*

注: •"*"表示低压进油口

•有阴影标注的油口规格可用于马达

•"✓"表示推荐油口形式,其余的油口形式请咨询上海毅鸥公司

•"140"或"175"表示油口最高工作压力为140bar或者175bar

MH75/76系列

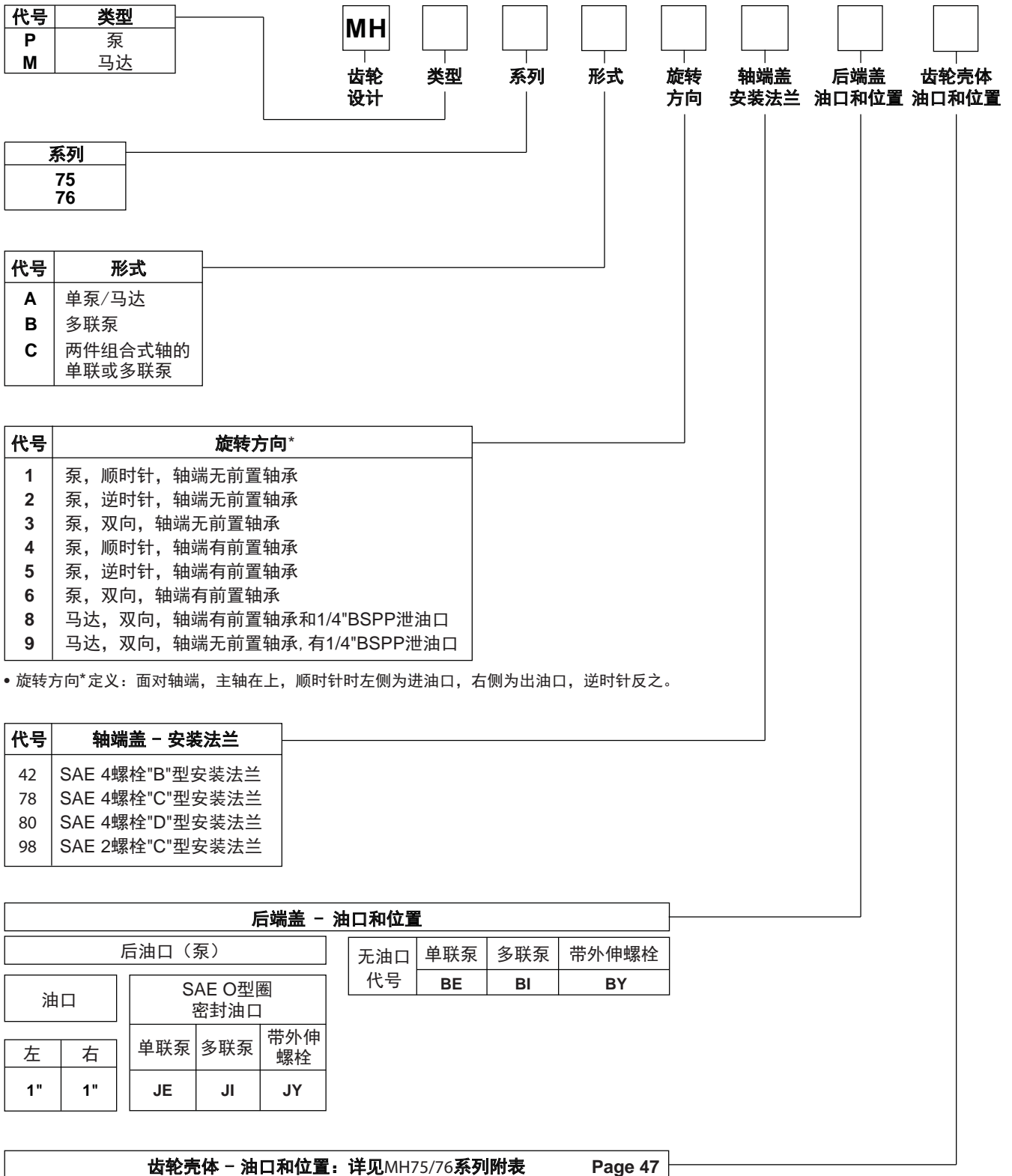

MH75/76系列

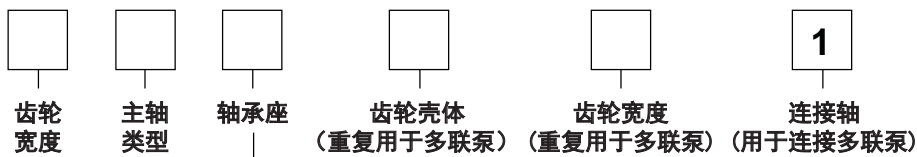

代号	齿轮宽度			
	齿轮宽度	排量 (cm ³ /rev)	最高压力(bar)	
			75系列	76系列
07	3/4"	50.3	175	210
10	1"	67.2	175	210
12	1-1/4"	83.9	175	210
15	1-1/2"	100.8	175	210
17	1-3/4"	117.5	175	210
20	2"	134.4	175	175
22	2-1/4"	151.1	158	175
25	2-1/2"	167.9	158	175
27	2-3/4"	184.7	140	140
30	3"	201.5	140	140

代号	主轴类型
07	SAE“C”型14齿花键, 外径31.75mm
11	SAE“C”型平键, 外径31.75mm, 键7.94x11.91x38.1mm

轴承座 - 油口规格和形式

单出口 (泵)					
油口		SAE O型圈密封油口		SAE美制拼合法兰油口	
		顺时针	逆时针	顺时针	逆时针
进	出				
1"	-	CB	BC	LB	BL
1-1/4"	-	DB	BD	MB	BM
1-1/2"	-	FB	BF	NB	BN
-	3/4"				
1"	3/4"	PJ	JP	BR	RB
1-1/4"	3/4"	CJ	JC	LR	RL
1-1/2"	3/4"	DJ	JD	MR	RM
1-1/2"	3/4"	FJ	JF	NR	RN
1-1/4"	1"	DK	KD	MS	SM
1-1/2"	1"	FK	KF	NS	SN
1"	3/4"				
1-1/4"	3/4"	CR	RC	LX	XL
1-1/2"	3/4"	DR	RD	MX	XM
1-1/4"	1"	FR	RF	-	-
1-1/2"	1"	DS	SD	MZ	ZM
1"	3/4"	FS	SF	NZ	ZN
1"	3/4"				
		-	-	SR	RS

单出口 (马达)			
SAE O型圈密封油口		双向	
进	出		
1"	1"	CC	
1-1/4"	1-1/4"	BB	
SAE型美制拼合法兰油口		双向	
进	出		
1"	1"	LL	
1-1/4"	1-1/4"	MM	
1-1/2"	1-1/2"	NN	
马达		双向	
无油口		B	

齿轮壳体 - 油口规格和形式																																
75 系列										75/76系列		76 系列																				
齿宽代码	07	10	12	15	17	20	22	25		27	30	07	10	12	15	17	20	22	25													
排量 (cc/rev)	50.3	67.2	83.9	100.8	117.5	134.4	151.1	167.9		184.7	201.5	50.3	67.2	83.9	100.8	117.5	134.4	151.1	167.9													
最大工作压力 (bar)	175	175	175	175	175	175	158	158		140	140	210	210	210	210	210	175	175	175													
进油口	出油口	顺时针	逆时针																无油口													
-	-	AB	AB	✓	✓	✓	✓	✓	✓	✓	✓	✓	✓	✓	✓	✓	✓	✓	✓	✓												
																			NPT油口													
3/4"	-	IC	ID	✓	✓	✓																✓	✓	✓								
-	3/4"	ID	IC	✓	✓	✓																✓	✓	✓								
1"	3/4"	IJ	IG	✓	✓	✓																✓	✓	✓								
1"	-	YC	YD		✓	✓	✓	✓																✓	✓	✓	✓					
-	1"	YD	YC		✓	✓	✓	✓																✓	✓	✓	✓					
1"	1"	YF	YF	✓	✓																✓	✓	✓									
1-1/4"	1"	YJ	YG		✓	✓																✓	✓									
1-1/4"	1-1/4"	YL	YL		✓	✓	✓	✓	✓	✓	✓	✓	✓	✓	✓	✓	✓	✓	✓	✓												
1-1/2"	1-1/2"	YR	YR				✓																✓	✓	✓							
																			SAE O型圈密封油口													
3/4"	-	EC	ED	✓	✓	✓	✓																✓	✓	✓	✓						
3/4"	3/4"	EF	EF	✓																✓												
1"*	3/4"	EJ	EG	✓*	✓	✓	✓																✓	175*	✓	✓						
1-1/4"*	3/4"	EK	EH		✓*																	✓*										
1"*	-	AC	AD			✓	✓																	175	✓							
-	1"	AD	AC			✓	✓																	175	✓							
1"	1"	AF	AF		140	✓	✓	✓	✓																✓	175	✓	✓	✓			
1-1/4"*	1"	AJ	AG		140*	✓*																	175*	✓*								
1-1/2"*	1"	AK	AH				✓*																	✓*								
1-1/4"	1-1/4"	AL	AL				140	140	140	✓	✓	✓	✓	✓	✓	✓	✓	✓	✓	✓												
1-1/2"*	1-1/4"	AP	AM				140*	140*																✓	✓							
1-1/2"	1-1/2"	AR	AR				✓	✓	✓	✓	✓	✓	✓	✓	✓	✓	✓	✓	✓	✓												
																			BSPP油口													
3/4"	-	YN	YQ	✓	✓	✓	✓	✓																✓	✓	✓						
-	3/4"	YQ	YN	✓	✓	✓	✓	✓																✓	✓	✓						
3/4"	3/4"	YS	YS																	✓												
1"*	3/4"	YV	YT	✓*	✓*	✓	✓	✓																✓*	✓*	✓	✓					
1"*	-	SL	RQ			✓	✓	✓	✓	✓	✓																✓*	✓*	✓	✓		
-	1"	RQ	SL			✓	✓	✓	✓	✓	✓																	✓	✓	✓		
1"	1"	MP	MP		140	✓	✓																	175	✓	✓						
1-1/4"*	1"	IX	VY		140*	✓*	✓*	✓	✓																✓	175*	✓*	✓*				
1-1/4"*	-	NJ	UI			✓*																									✓	
-	1-1/4"	UI	NJ																										✓			
1-1/4"	1-1/4"	PF	PF				140	140	✓	✓																-/✓			✓	✓		
1-1/2"*	1"	VI	HW			✓*	✓*	✓*																			✓*					
1-1/2"*	1-1/4"	IS	IQ				140*	140*	✓*																			✓*				

- 注:
- "*"表示低压进油口
 - "✓"表示推荐油口形式, 其余的油口形式请咨询上海毅鸥公司
 - NPT油口建议用在压力低于103bar(1500psi)的情况下
 - 有阴影标注的油口规格可用于马达
 - "140"或"175"表示油口最高工作压力为140bar或者175bar

MH75/76系列

齿轮壳体 - 油口规格和形式																			
		75 系列								75/76系列		76 系列							
齿宽代码		07	10	12	15	17	20	22	25	27	30	07	10	12	15	17	20	22	25
排量 (cc/rev)		50.3	67.2	83.9	100.8	117.5	134.4	151.1	167.9	184.7	201.5	50.3	67.2	83.9	100.8	117.5	134.4	151.1	167.9
最大工作压力 (bar)		175	175	175	175	175	175	158	158	140	140	210	210	210	210	210	175	175	175
进油口	出油口	顺时针	逆时针	SAE美制拼合法兰油口															
3/4"	-	UC	UD	✓	✓	✓	✓					✓	✓	✓	✓				
-	3/4"	UD	UC	✓	✓	✓	✓					✓	✓	✓	✓				
1"	3/4"	UJ	UG	✓	✓	✓	✓	✓				✓	✓	✓	✓	✓			
1"	-	OC	OD	✓	✓	✓	✓	✓				✓	✓	✓	✓	✓			
-	1"	OD	OC	✓	✓	✓	✓	✓				✓	✓	✓	✓	✓			
1"	1"	OF	OF	✓	✓	✓	✓	✓	✓	✓/✓	✓/✓	✓	✓	✓	✓	✓	✓	✓	✓
1-1/4"	1"	OJ	OG	140*	✓	✓	✓	✓	✓			✓*	✓*	✓	✓	✓	✓	✓	✓
1-1/2"	1"	OK	OH		✓*	✓*	✓*	✓	✓			✓*	✓*	✓*	✓	✓	✓	✓	✓
1-1/4"	-	OA	OB		✓	✓	✓	✓	✓			✓	✓	✓	✓	✓	✓	✓	✓
-	1-1/4"	OB	OA		✓	✓	✓	✓	✓			✓	✓	✓	✓	✓	✓	✓	✓
1-1/4"	1-1/4"	OL	OL		✓	✓	✓	✓	✓	✓/✓	✓/✓			175	✓	✓	✓	✓	✓
1-1/2"	1-1/4"	OP	OM		✓*	✓*	✓*	✓	✓	✓/✓	✓/✓			175*	✓*	✓*	✓	✓	✓
1-1/2"	-	OE	OU				✓	✓							✓	✓			
-	1-1/2"	OU	OE				✓	✓							✓	✓			
1-1/2"	1-1/2"	OR	OR			140	✓	✓	✓	✓/✓	✓/✓				✓	✓	✓	✓	✓
2"	1"	UQ	-					✓*											
2"	1-1/4"	OQ	ON				✓*	✓*	✓*	✓/✓	✓/✓				✓*	✓*	✓*	✓	✓
2"	1-1/2"	OV	OS			140*	✓*	✓*	✓*	✓/✓	✓/✓				✓*	✓*	✓*	✓	✓
2"	2"	OX	OX						✓	✓/✓	✓/✓								✓
2-1/2"	1-1/4"	US	UN						✓*										✓*
2-1/2"	1-1/2"	OW	OT						✓*	✓*/✓*	✓*/✓*								✓*
2-1/2"	2"	OZ	OY							✓*/✓*	✓*/✓*								✓*
				SAE公制拼合法兰油口															
3/4"	-	VN	VQ	✓	✓	✓	✓												
-	3/4"	VQ	VN	✓	✓	✓	✓												
1"	3/4"	RV	VT	✓	✓	✓	✓	✓	✓				✓						
1"	-	UL	UR		✓	✓	✓	✓	✓										
-	1"	UR	UL		✓	✓	✓	✓	✓										
1"	1"	UM	UM		✓	✓	✓	✓	✓				✓	✓	✓	✓			
1-1/4"	1"	UX	VU		✓*	✓	✓	✓	✓	✓	✓			✓*	✓*				
1-1/2"	1"	VO	HO			✓*	✓*							✓*	✓*				
1-1/4"	-	NO	UO		✓	✓	✓	✓	✓										
-	1-1/4"	UO	NO		✓	✓	✓	✓	✓										
1-1/4"	1-1/4"	PO	PO		✓	✓	✓	✓	✓	✓/✓	✓/✓			175	✓	✓	✓	✓	✓
1-1/2"	1-1/4"	SO	QO			✓*	✓*	✓	✓	✓	✓			175*	✓*	✓*			
1-1/2"	-	UY	TO					✓	✓	✓	✓					✓*	✓		
-	1-1/2"	TO	UY					✓	✓	✓	✓					✓			
1-1/2"	1-1/2"	SV	SV				140	✓	✓	✓/✓*	✓/✓*					✓	✓		✓
2"	1-1/4"	JM	JR				✓*	✓*	✓*	✓*	✓*				✓*	✓*	✓*		
2"	1-1/2"	JQ	JN				140*	✓*	✓*	✓*	✓*					✓*	✓*		
2"	2"	JS	JS							✓/✓	✓/✓								
2-1/2"	1-1/2"	LJ	JX							✓*/✓*	✓*/✓*								✓*

注： • “*” 表示低压进油口
 • “✓” 表示推荐油口形式，其余的油口形式请咨询上海毅鸥公司
 • 有阴影标注的油口规格可用于马达
 • “140”或“175”表示油口最高工作压力为140bar或者175bar

MH315系列

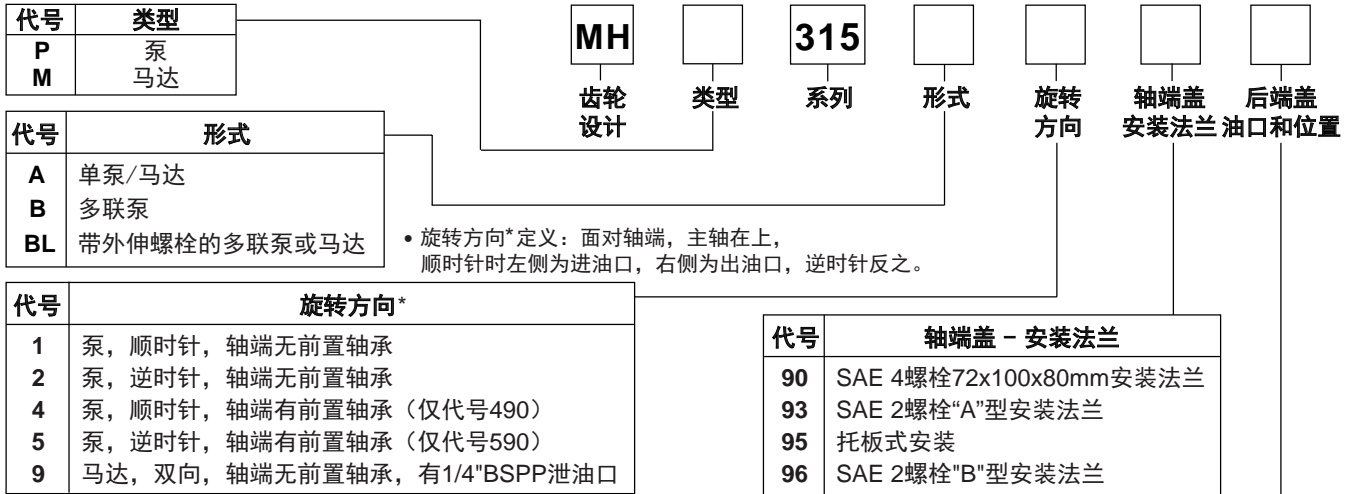

后端盖 - 油口规格和位置

侧油口 (泵)														后油口 (泵)			
油口		SAE O型圈密封油口		BSPP油口		SAE美制拼合法兰油口		NPT油口		SAE公制拼合法兰油口		SAE O型圈密封油口		BSPP油口			
进	出	顺时针	逆时针	顺时针	逆时针	顺时针	逆时针	顺时针	逆时针	顺时针	逆时针	顺时针	逆时针	顺时针	逆时针		
1-1/4"	1"	FB	BF	FN	NF	-	-	AJ	JA	-	-	UC	CU	US	SU		
1-1/4"	7/8"	FC	CF	FP	PF	-	-	-	-	-	-	UF	FU	UT	TU		
1-1/4"	3/4"	FG	GF	FR	RF	-	-	AK	KA	-	-	UN	NU	UV	VU		
1-1/4"	5/8"	FJ	JF	-	-	-	-	-	-	-	-	-	-	-	-		
1"	1"	FL	LF	FS	SF	-	-	AL	LA	-	-	UD	DU	UW	WU		
1"	7/8"	FV	VF	FT	TF	-	-	-	-	-	-	UP	PU	UX	XU		
1"	3/4"	FW	WF	BP	PB	EJ	JE	AM	MA	EV	VE	UQ	QU	UY	YU		
1"	5/8"	FX	XF	-	-	-	-	-	-	-	-	UR	RU	-	-		
1"	1/2"	-	-	-	-	EK	KE	-	-	EW	WE	-	-	-	-		
7/8"	7/8"	FY	YF	BQ	QB	-	-	-	-	-	-	LN	NL	LU	UL		
7/8"	3/4"	FZ	ZF	BR	RB	-	-	-	-	-	-	LP	PL	LV	VL		
7/8"	5/8"	BC	CB	-	-	-	-	-	-	-	-	LQ	QL	-	-		
7/8"	1/2"	BG	GB	BT	TB	-	-	-	-	-	-	-	-	-	-		
3/4"	3/4"	BJ	JB	BU	UB	EL	LE	AR	RA	EX	XE	LR	RL	LX	XL		
3/4"	5/8"	BL	LB	-	-	-	-	-	-	-	-	LS	SL	-	-		
3/4"	1/2"	BN	NB	PQ	QP	EM	ME	-	-	EY	YE	LT	TL	LZ	ZL		
1-1/4"	-	BV	VB	PR	RP	-	-	-	-	-	-	-	-	-	-		
1"	-	BW	WB	PS	SP	OE	EO	-	-	OP	PO	-	-	-	-		
7/8"	-	BX	XB	PT	TP	-	-	-	-	-	-	-	-	-	-		
3/4"	-	BY	YB	PV	VP	-	-	-	-	OR	RO	-	-	-	-		
-	1"	BZ	ZB	PW	WP	-	-	-	-	-	-	-	-	-	-		
-	7/8"	PD	DP	PX	XP	-	-	-	-	-	-	-	-	-	-		
-	3/4"	PE	EP	PY	YP	OJ	JO	-	-	OT	TO	-	-	-	-		
-	5/8"	PM	MP	-	-	-	-	-	-	-	-	-	-	-	-		
-	1/2"	PN	NP	PZ	ZP	OL	LO	-	-	OV	VO	-	-	-	-		

无油口 BI

侧油口 (马达, 双向旋转)

后油口 (马达, 双向旋转)

油口		SAE O型圈密封油口	BSPP油口	SAE美制拼合法兰油口	NPT油口	SAE公制拼合法兰油口	SAE O型圈密封油口	BSPP油口	NPT油口
进	出								
1"	1"	VN	VY	DR	DM	DV	RN	RT	RX
3/4"	3/4"	VR	VZ	DS	DN	DW	RQ	RV	RY
1/2"	1/2"	VQ	VV	-	DQ	-	RS	RW	RZ

MH315系列

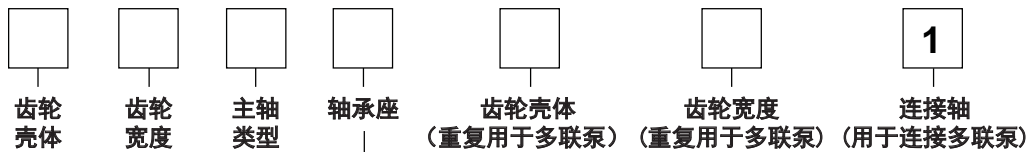

代号	齿轮壳体
AB	泵
EB	马达

代号	齿轮宽度		
	齿轮宽度	排量 (cm ³ /rev)	最高压力 (bar)
03	3/8"	7.7	245
05	1/2"	10.2	245
06	5/8"	12.8	245
07	3/4"	15.2	245
08	7/8"	17.9	245
10	1"	20.3	245
11	1-1/8"	22.9	245
12	1-1/4"	25.4	245
13	1-3/8"	28.0	245
15	1-1/2"	30.5	231
16	1-5/8"	33.1	217
17	1-3/4"	35.6	203
18	1-7/8"	38.2	189
20	2"	40.6	175

代号	主轴类型
97	SAE "A" 型平键
96	SAE "A" 型花键
66	SAE "B" 型平键
65	SAE "B" 型花键

轴承座 - 油口规格和形式

双出口 (泵)	单出口 (泵)
---------	---------

注意: 出口: 对于顺时针, 顶部油口为前泵出口口, 对于逆时针, 底部油口为前泵出口口

注意: 出口用于前泵

油口			SAE O型圈密封油口		BSPB油口		SAE美制拼合法兰油口		SAE公制拼合法兰油口		油口			SAE O型圈密封油口		BSPB油口		SAE美制拼合法兰油口		SAE公制拼合法兰油口	
			顺时针	逆时针	顺时针	逆时针	顺时针	逆时针	顺时针	逆时针				进	出	顺时针	逆时针	顺时针	逆时针	顺时针	逆时针
1-1/2"	1"	1"	JG	GJ	HJ	JH	-	-	-	-	1-1/2"	1-1/2"	KB	BK	KR	RK	-	-	-	-	
1-1/2"	1"	7/8"	KG	GK	KJ	JK	-	-	-	-	1-1/2"	1-1/4"	KC	CK	KS	SK	-	-	-	-	
1-1/2"	7/8"	7/8"	LG	GL	LJ	JL	-	-	-	-	1-1/2"	1"	KF	FK	KT	TK	-	-	-	-	
1-1/2"	1"	3/4"	MG	GM	MJ	JM	-	-	-	-	1-1/2"	7/8"	KL	LK	KU	UK	-	-	-	-	
1-1/2"	3/4"	3/4"	NG	GN	NJ	JN	-	-	-	-	1-1/2"	3/4"	KM	MK	KV	VK	-	-	-	-	
1-1/4"	1"	1"	PG	GP	PJ	JP	-	-	-	-	1-1/4"	1-1/4"	KN	NK	KW	WK	CJ	JC	CN	NC	
1-1/4"	1"	7/8"	QQ	QJ	QJ	JQ	-	-	-	-	1-1/4"	1"	KO	OK	KX	XK	CL	LC	CP	PC	
1-1/4"	7/8"	7/8"	RG	GR	RJ	JR	-	-	-	-	1-1/4"	7/8"	KP	PK	KY	YK	-	-	-	-	
1-1/4"	1"	3/4"	SG	GS	SJ	JS	-	-	-	-	1-1/4"	3/4"	KQ	QK	KZ	ZK	CM	MC	CQ	QC	
1-1/4"	3/4"	3/4"	TG	GT	TJ	JT	CA	AC	BD	DB	1-1/4"	5/8"	MB	BM	-	-	-	-	-	-	
1-1/4"	3/4"	5/8"	UG	GU	-	-	-	-	-	-	1-1/4"	1/2"	ML	LM	HO	OH	HB	BH	HR	RH	
1-1/4"	3/4"	1/2"	VG	GV	UJ	JU	DA	AD	CD	DC	1"	1"	MN	NM	HP	PH	HC	CH	HS	SH	
1-1/4"	5/8"	5/8"	WG	GW	-	-	-	-	-	-	1"	7/8"	MQ	QM	HQ	QH	-	-	-	-	
1-1/4"	1/2"	1/2"	XG	GX	VJ	JV	EA	AE	ED	DE	1"	3/4"	MR	RM	HX	XH	HF	FH	HT	TH	
1"	1"	1"	YG	GY	WJ	JW	-	-	-	-	1"	5/8"	MS	SM	-	-	-	-	-	-	
1"	1"	7/8"	ZG	GZ	XJ	JX	-	-	-	-	1"	1/2"	MT	TM	HY	YH	HL	LH	HU	UH	
1"	7/8"	7/8"	RC	CR	YJ	JY	-	-	-	-	3/4"	3/4"	MU	UM	HZ	ZH	HM	MH	HV	VH	
1"	1"	3/4"	SC	CS	ZJ	JZ	-	-	-	-	3/4"	5/8"	MV	VM	-	-	-	-	-	-	
1"	3/4"	3/4"	TC	CT	JD	DJ	FA	AF	FD	DF	3/4"	1/2"	MW	WM	MX	XM	HN	NH	HW	WH	
1"	3/4"	5/8"	VC	CV	-	-	-	-	-	-	公用吸油口		顺时针	逆时针							
1"	5/8"	5/8"	XC	CX	-	-	-	-	-	-	无油口		C	D							
1"	3/4"	1/2"	WC	CW	KD	DK	GA	AG	GD	DG											
1"	1/2"	1/2"	YC	CY	LD	DL	HA	AH	HD	DH											

MH330系列

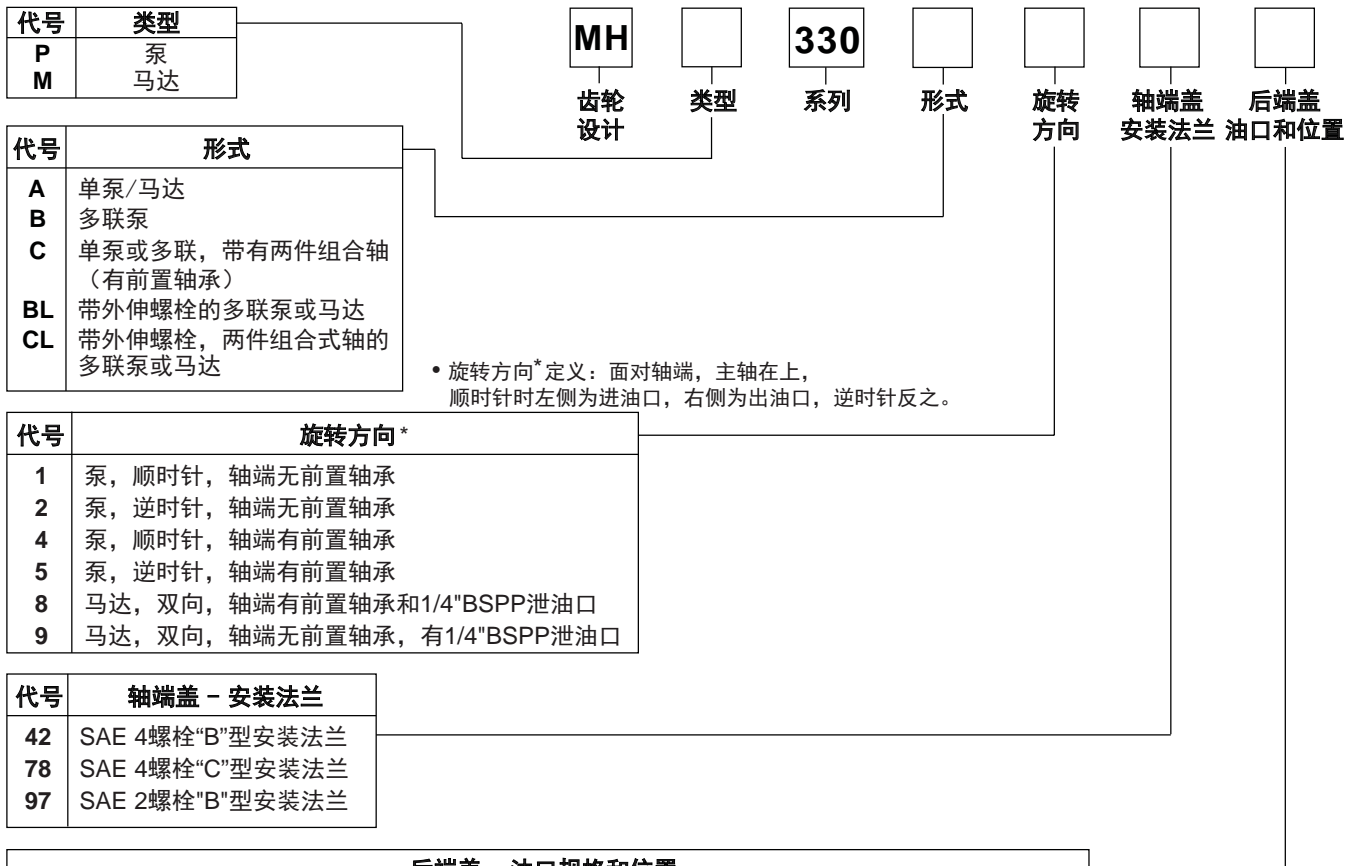

后端盖 - 油口规格和位置

侧油口 (泵)

油口		SAE O型圈密封油口		BSPP油口		SAE美制拼合法兰油口		SAE公制拼合法兰油口		NPT油口	
		顺时针	逆时针	顺时针	逆时针	顺时针	逆时针	顺时针	逆时针	顺时针	逆时针
进	出										
1-1/2"	1-1/4"	-	-	-	-	EJ	JE	EV	VE	-	-
1-1/2"	1"	-	-	-	-	EK	KE	EW	WE	-	-
1-1/4"	1-1/4"	-	-	-	-	EL	LE	EX	XE	-	-
1-1/4"	1"	FJ	JF	FS	SF	EM	ME	EY	YE	AJ	JA
1-1/4"	3/4"	-	-	-	-	-	-	-	-	AK	KA
1"	1"	FL	LF	FT	TF	EN	NE	EZ	ZE	AL	LA
1"	3/4"	-	-	-	-	-	-	-	-	AM	MA
3/4"	3/4"	-	-	-	-	-	-	-	-	AR	RA
1-1/2"	-	-	-	-	-	OF	FO	OR	RO	-	-
1-1/4"	-	BG	GB	BQ	QB	OG	GO	OS	SO	-	-
1"	-	BJ	JB	BR	RB	OJ	JO	OT	TO	-	-
-	1-1/4"	-	-	-	-	OM	MO	OW	WO	-	-
-	1"	BN	NB	BU	UB	ON	NO	OX	XO	-	-

无油口 **BI**

侧油口 (马达, 双向旋转)

油口		SAE O型圈密封油口	SAE美制拼合法兰油口	NPT油口	SAE公制拼合法兰油口
进	出				
1-1/2"	1-1/2"	-	-	DQ	-
1-1/4"	1-1/4"	VC	CS	DM	CX
1"	1"	VN	CT	DN	CY
3/4"	3/4"	VR	CV	-	CZ

MH330系列

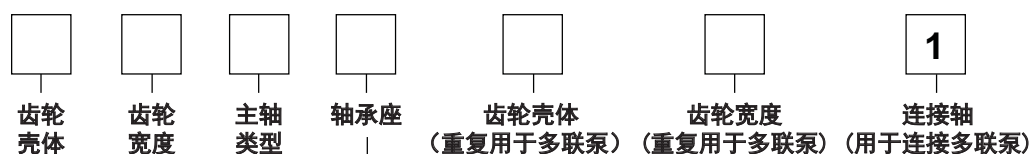

代号	齿轮壳体
AB	泵
EB	马达

齿轮宽度			
代号	齿轮宽度	排量 (cm ³ /rev)	最高压力 (bar)
05	1/2"	16.2	245
07	3/4"	24.2	245
10	1"	32.3	245
12	1-1/4"	40.3	245
15	1-1/2"	48.5	245
17	1-3/4"	56.5	228
20	2"	64.6	210

代号	主轴类型
07	SAE "C" 型花键
25	SAE "B" 型花键
30	SAE "B" 型平键
98	SAE "BB" 型花键
43	SAE "BB" 型平键

轴承座 - 油口规格和形式

双出口 (泵)				单出口 (泵)				前后泵出口合流			
注意: 出口: 对于顺时针, 顶部油口为前泵出口口, 对于逆时针, 底部油口为前泵出口口				注意: 出口用于前泵							

油口			SAE美制拼合法兰油口		SAE公制拼合法兰油口		SAE O型圈密封油口		油口			SAE美制拼合法兰油口		SAE公制拼合法兰油口		SAE O型圈密封油口		SAE美制拼合法兰油口		SAE O型圈密封油口	
			顺时针	逆时针	顺时针	逆时针	顺时针	逆时针				顺时针	逆时针	顺时针	逆时针	顺时针	逆时针	顺时针	逆时针	顺时针	逆时针
进	出	出	AM	MA	DM	MD	-	-	2"	1-1/2"	HB	BH	HR	RH	-	-	UN	NU	-	-	
2"	1-1/4"	1-1/4"	AN	NA	DN	ND	-	-	2"	1-1/4"	HC	CH	HS	SH	-	-	UO	OU	-	-	
2"	1-1/4"	1"	AP	PA	DP	PD	-	-	2"	1"	HF	FH	HT	TH	-	-	-	-	-	-	
2"	1"	1"	AT	TA	DT	TD	-	-	1-1/2"	1-1/2"	HL	LH	HU	UH	-	-	UP	PU	-	-	
1-1/2"	1-1/4"	1-1/4"	AU	UA	DU	UD	-	-	1-1/2"	1-1/4"	HM	MH	HV	VH	KM	MK	UQ	QU	PQ	QP	
1-1/2"	1-1/4"	1"	AV	VA	DV	VD	GV	VG	1-1/2"	1"	HN	NH	HW	WH	KN	NK	-	-	-	-	
1-1/2"	1"	1"	AW	WA	DW	WD	-	-	1-1/4"	1-1/4"	HO	OH	HX	XH	KO	OK	UR	RU	PR	RP	
1-1/4"	1-1/4"	1-1/4"	AX	XA	DX	XD	-	-	1-1/4"	1"	HP	PH	HY	YH	KP	PK	-	-	-	-	
1-1/4"	1-1/4"	1"	AY	YA	-	-	GY	YG	1-1/4"	1"	HQ	QH	HZ	ZH	KQ	QK	-	-	-	-	
1-1/4"	1"	1"	AZ	ZA	-	-	GZ	ZG	1"	1"											
1"	1"	1"			DZ	ZD															

公用吸油口	顺时针	逆时针
无油口	C	D

出口合流 (马达、双向旋转)

油口		SAE O型圈密封油口	BSPP 油口	SAE美制拼合法兰油口	SAE公制拼合法兰油口
进	出				
1-1/2"	1-1/2"	-	-	BB	HH
1-1/4"	1-1/4"	NN	XX	CC	JJ
1"	1"	QQ	YY	EE	KK
3/4"	3/4"	RR	ZZ	FF	LL

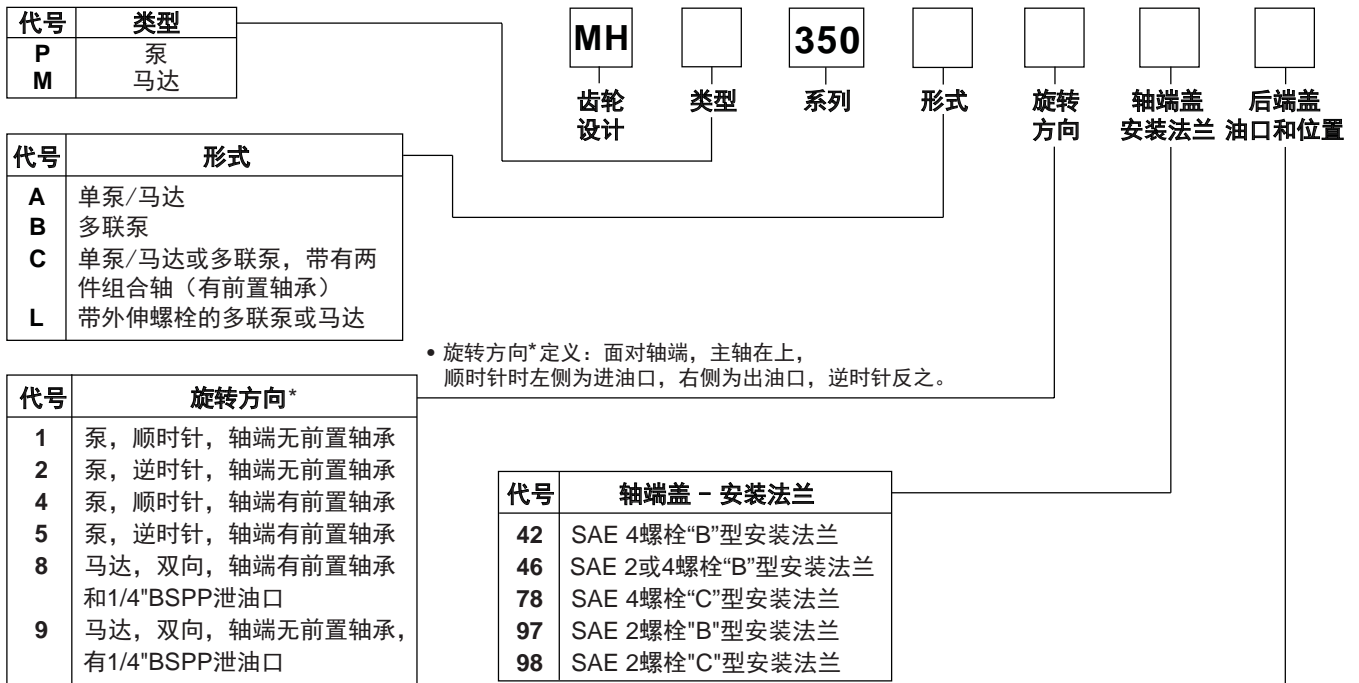

后端盖 - 油口规格和位置

侧油口（泵）

油口		SAE O型圈密封油口		BSPP油口		SAE美制拼合法兰油口		SAE公制拼合法兰油口	
		顺时针	逆时针	顺时针	逆时针	顺时针	逆时针	顺时针	逆时针
进	出								
2"	1-1/2"	-	-	-	-	EC	CE	ER	RE
2"	1-1/4"	-	-	-	-	EF	FE	ES	SE
2"	1"	-	-	-	-	EG	GE	ET	TE
1-1/2"	1-1/2"	-	-	-	-	EH	HE	EU	UE
1-1/2"	1-1/4"	FB	BF	FN	NF	EJ	JE	EV	VE
1-1/2"	1"	FC	CF	FP	PF	EK	KE	EW	WE
1-1/4"	1-1/4"	FG	GF	FR	RF	EL	LE	EX	XE
1-1/4"	1"	FJ	JF	FS	SF	EM	ME1	EY	YE
1"	1"	FL	LF	FT	TF	EN	NE	EZ	ZE
2"	-	-	-	-	-	OE	EO	OP	PO
1-1/2"	-	BC	CB	BP	PB	OF	FO	OR	RO
1-1/4"	-	BG	GB	BQ	QB	OG	GO	OS	SO
1"	-	BJ	JB	BR	RB	OJ	JO	OT	TO
-	1-1/2"	-	-	-	-	OL	LO	OV	VO
-	1-1/4"	BL	LB	BT	TB	OM	MO	OW	WO
-	1"	BN	NB	BU	UB	ON	NO	OX	XO

无油口 顺时针 BI 逆时针 IB

侧油口（马达，双向旋转）

油口		SAE O型圈密封油口	SAE美制拼合法兰油口	BSPP油口	SAE公制拼合法兰油口
进	出				
1-1/2"	1-1/2"	-	CR	-	CW
1-1/4"	1-1/4"	VC	CS	VC	CX
1"	1"	VN	CT	VN	CY
3/4"	3/4"	VR	CV	VR	CZ

MH350系列

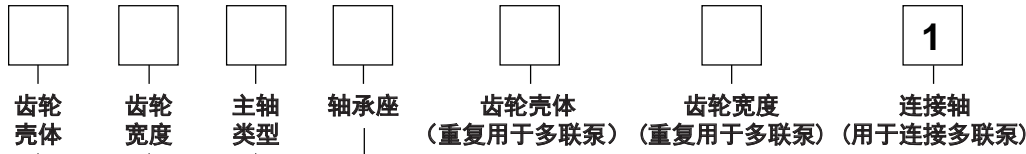

代号	齿轮壳体
AB	泵
EB	马达

齿轮宽度			
代号	齿轮宽度	排量 (cm ³ /rev)	最高压力 (bar)
05	1/2"	21.0	245
07	3/4"	31.3	245
10	1"	41.8	245
12	1-1/4"	52.3	245
15	1-1/2"	62.8	245
17	1-3/4"	73.1	228
20	2"	83.6	210
22	2-1/4"	94.0	193
25	2-1/2"	104.5	175

代号	主轴类型
07	SAE "C" 型花键
11	SAE "C" 型平键
25	SAE "B" 型花键
43	SAE "BB" 型平键
73	SAE "C" 型长平键
98	SAE "BB" 型花键

轴承座 - 油口规格和形式

双出口 (泵)	单出口 (泵)	前后泵出口合流
注意: 出口: 对于顺时针, 顶部油口为前泵出口口, 对于逆时针, 底部油口为前泵出口口		注意: 出口用于前泵

油口			SAE美制拼合法兰油口			SAE公制拼合法兰油口			SAE O型圈密封油口			油口		SAE美制拼合法兰油口		BSPP油口		SAE O型圈密封油口		SAE美制拼合法兰油口		SAE O型圈密封油口	
进	出	出	顺时针	逆时针	顺时针	逆时针	顺时针	逆时针	顺时针	逆时针	进	出	顺时针	逆时针	顺时针	逆时针	顺时针	逆时针	顺时针	逆时针	顺时针	逆时针	
2-1/2"	1-1/4"	1-1/4"	AF	FA	-	-	-	-	2"	1-1/2"	HB	BH	KR	RK	KB	BK	UN	NU	PE	EP			
2-1/2"	1-1/4"	1"	AG	GA	-	-	-	-	2"	1-1/4"	HC	CH	KS	SK	KC	CK	UO	OU	PM	MP			
2-1/2"	1"	1"	AH	HA	-	-	-	-	2"	1"	HF	FH	KT	TK	KF	FK	-	-	-	-			
2"	1-1/4"	1-1/4"	AM	MA	DM	MD	GM	MG	1-1/2"	1-1/2"	HL	LH	KU	UK	KL	LK	UP	PU	PN	NP			
2"	1-1/4"	1"	AN	NA	DN	ND	GN	NG	1-1/2"	1-1/4"	HM	MH	KV	VK	KM	MK	UQ	QU	PQ	QP			
2"	1"	1"	AP	PA	DP	PD	GP	PG	1-1/2"	1"	HN	NH	KW	WK	KN	NK	-	-	-	-			
1-1/2"	1-1/4"	1-1/4"	AT	TA	DT	TD	GT	TG	1-1/4"	1-1/4"	HO	OH	KX	XK	KO	OK	UR	RU	PR	RP			
1-1/2"	1-1/4"	1"	AU	UA	DU	UD	GU	UG	1-1/4"	1"	HP	PH	KY	YK	KP	PK	-	-	-	-			
1-1/2"	1"	1"	AV	VA	DV	VD	GV	VG	1"	1"	HQ	QH	KZ	ZK	KQ	QK	-	-	-	-			
1-1/4"	1-1/4"	1-1/4"	AW	WA	DW	WD	GW	WG	1-1/4"	1"	RS	SR	-	-	-	-	-	-	-	-			
1-1/4"	1-1/4"	1"	AX	XA	DX	XD	GX	XG															
1-1/4"	1"	1"	AY	YA	DY	YD	GY	YG															
1"	1"	1"	AZ	ZA	DZ	ZD	GZ	ZG															
									公用吸油口		顺时针	逆时针											
									无油口		C	D											

出口合流 (马达、双向旋转)

油口		SAE O型圈密封油口	BSPP油口	SAE美制拼合法兰油口	SAE公制拼合法兰油口
进	出				
2"	2"	-	-	AA	GG
1-1/2"	1-1/2"	MM	WW	BB	HH
1-1/4"	1-1/4"	NN	XX	CC	JJ
1"	1"	QQ	YY	EE	KK
3/4"	3/4"	RR	ZZ	FF	LL

MH365系列

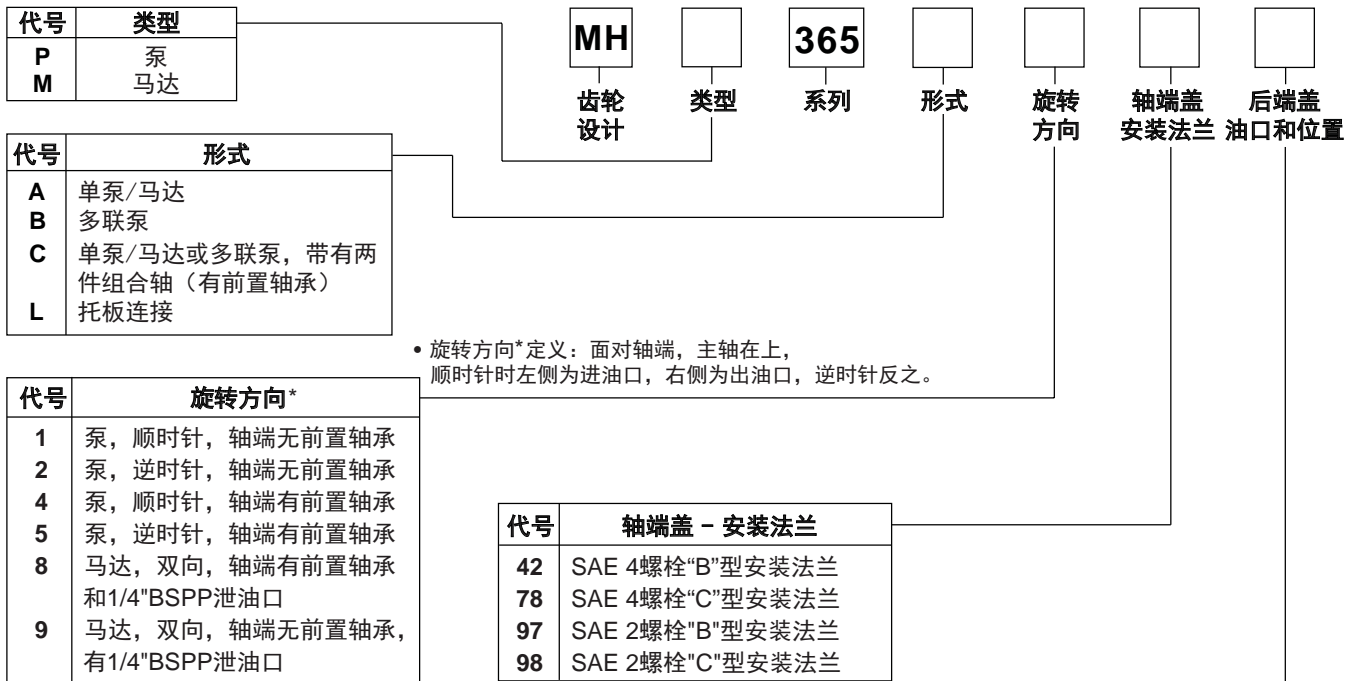

后端盖 - 油口规格和位置

侧油口（泵）

油口		SAE O型圈密封油口		BSPP油口		SAE美制拼合法兰油口		SAE公制拼合法兰油口	
		顺时针	逆时针	顺时针	逆时针	顺时针	逆时针	顺时针	逆时针
进	出								
2"	1-1/2"	-	-	-	-	EC	CE	ER	RE
2"	1-1/4"	-	-	-	-	EF	FE	ES	SE
2"	1"	-	-	-	-	EG	GE	ET	TE
1-1/2"	1-1/2"	-	-	-	-	EH	HE	EU	UE
1-1/2"	1-1/4"	FB	BF	FN	NF	EJ	JE	EV	VE
1-1/2"	1"	FC	CF	FP	PF	EK	KE	EW	WE
1-1/4"	1-1/4"	FG	GF	FR	RF	EL	LE	EX	XE
1-1/4"	1"	FJ	JF	FS	SF	EM	ME	EY	YE
1"	1"	FL	LF	FT	TF	EN	NE	EZ	ZE
2"	-	-	-	-	-	OE	EO	OP	PO
1-1/2"	-	BC	CB	BP	PB	OF	FO	OR	RO
1-1/4"	-	BG	GB	BQ	QB	OG	GO	OS	SO
1"	-	BJ	JB	BR	RB	OJ	JO	OT	TO
-	1-1/2"	-	-	-	-	OL	LO	OV	VO
-	1-1/4"	BL	LB	BT	TB	OM	MO	OW	WO
-	1"	BN	NB	BU	UB	ON	NO	OX	XO

无油口 顺时针 BI 逆时针 IB

侧油口（马达，双向旋转）

油口		SAE O型圈密封油口	SAE美制拼合法兰油口	BSPP油口	SAE公制拼合法兰油口
进	出				
1-1/2"	1-1/2"	-	CR	-	CW
1-1/4"	1-1/4"	VC	CS	VX	CX
1"	1"	VN	CT	VY	CY
3/4"	3/4"	VR	CV	VZ	CZ

MH365系列

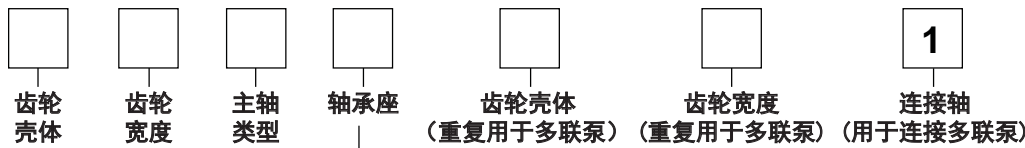

代号	齿轮壳体
AB	泵
EB	马达

齿轮宽度			
代号	齿轮宽度	排量 (cm ³ /rev)	最高压力(bar)
07	3/4"	44.2	245
10	1"	59.0	245
12	1-1/4"	73.7	245
15	1-1/2"	88.5	245
17	1-3/4"	103.2	245
20	2"	118.0	245
22	2-1/4"	132.7	228
25	2-1/2"	147.5	210

代号	主轴类型
07	SAE "C" 型花键
11	SAE "C" 型平键

轴承座 - 油口规格和形式

双出口 (泵)

注意: 出口: 对于顺时针, 顶部油口为前泵出油口, 对于逆时针, 底部油口为前泵出油口

油口			SAE美制拼合法兰油口		SAE公制拼合法兰油口		SAE O型圈密封油口		BSP油口	
进	出	出	顺时针	逆时针	顺时针	逆时针	顺时针	逆时针	顺时针	逆时针
2-1/2"	1-1/2"	1-1/2"	AC	CA	DB	BD	-	-	-	-
2-1/2"	1-1/2"	1-1/4"	AD	DA	DC	CD	-	-	-	-
2-1/2"	1-1/2"	1"	AE	EA	DE	ED	-	-	-	-
2-1/2"	1-1/4"	1-1/4"	AF	FA	DF	FD	-	-	-	-
2-1/2"	1-1/4"	1"	AG	GA	DG	GD	-	-	-	-
2-1/2"	1"	1"	AH	HA	DH	HD	-	-	-	-
2"	1-1/2"	1-1/2"	AJ	JA	DJ	JD	GJ	JG	JH	HJ
2"	1-1/2"	1-1/4"	AK	KA	DK	KD	GK	KG	JK	KJ
2"	1-1/2"	1"	AL	LA	DL	LD	GL	LG	JL	LJ
2"	1-1/4"	1-1/4"	AM	MA	DM	MD	GM	MG	JM	MJ
2"	1-1/4"	1"	AN	NA	DN	ND	GN	NG	JN	NJ
2"	1"	1"	AP	PA	DP	PD	GP	PG	JP	PJ
1-1/2"	1-1/2"	1-1/2"	AQ	QA	DQ	QD	GQ	QG	JQ	QJ
1-1/2"	1-1/2"	1-1/4"	AR	RA	DR	RD	GR	RG	JR	RJ
1-1/2"	1-1/2"	1"	AS	SA	DS	SD	GS	SG	JS	SJ
1-1/2"	1-1/4"	1-1/4"	AT	TA	DT	TD	GT	TG	JT	TJ
1-1/2"	1-1/4"	1"	AU	UA	DU	UD	GU	UG	JU	UJ
1-1/2"	1"	1"	AV	VA	DV	VD	GV	VG	JV	VJ
1-1/4"	1-1/4"	1-1/4"	AW	WA	DW	WD	GW	WG	JW	WJ
1-1/4"	1-1/4"	1"	AX	XA	DX	XD	GX	XG	JX	XJ
1-1/4"	1"	1"	AY	YA	DY	YD	GY	YG	JY	YJ
1"	1"	1"	AZ	ZA	DZ	ZD	GZ	ZG	JZ	ZJ

单出口 (泵)

注意: 出口用于前泵

油口			SAE美制拼合法兰油口		SAE公制拼合法兰油口		SAE O型圈密封油口	
进	出	出	顺时针	逆时针	顺时针	逆时针	顺时针	逆时针
2-1/2"	1-1/2"	1-1/2"	CJ	JC	CN	NC	-	-
2-1/2"	1-1/4"	1-1/4"	CL	LC	CP	PC	-	-
2-1/2"	1"	1"	CM	MC	CQ	QC	-	-
2"	1-1/2"	1-1/2"	HB	BH	HR	RH	KB	BK
2"	1-1/4"	1-1/4"	HC	CH	HS	SH	KC	CK
2"	1"	1"	HF	FH	HT	TH	KF	FK
1-1/2"	1-1/2"	1-1/2"	HL	LH	HU	UH	KL	LK
1-1/2"	1-1/4"	1-1/4"	HM	MH	HV	VH	KM	MK
1-1/2"	1"	1"	HN	NH	HW	WH	KN	NK
1-1/4"	1-1/4"	1-1/4"	HO	OH	HX	XH	KO	OK
1-1/4"	1"	1"	HP	PH	HY	YH	KP	PK
1"	1"	1"	HQ	QH	HZ	ZH	KQ	QK

前后泵出口合流

油口		SAE美制拼合法兰油口		SAE O型圈密封油口	
进	出	顺时针	逆时针	顺时针	逆时针
2-1/2"	1-1/2"	UC	CU	-	-
2-1/2"	1-1/4"	UF	FU	-	-
2"	1-1/2"	UN	NU	PE	EP
2"	1-1/4"	UO	OU	PM	MP
1-1/2"	1-1/2"	UP	PU	PN	NP
1-1/2"	1-1/4"	UQ	QU	PQ	QP
1-1/4"	1-1/4"	UR	RU	PR	RP

出口合流 (马达、双向旋转)

油口		SAE O型圈密封油口	BSP油口	SAE美制拼合法兰油口	SAE公制拼合法兰油口
进	出				
2"	2"	-	-	AA	GG
1-1/2"	1-1/2"	MM	WW	BB	HH
1-1/4"	1-1/4"	NN	XX	CC	JJ
1"	1"	QQ	YY	EE	KK
3/4"	3/4"	RR	ZZ	FF	LL

公用吸油口	顺时针	逆时针
无油口	C	D

双联齿轮泵的类型与结构

麦塔雷斯双联齿轮泵是前后两个泵共享同一传动系统。麦塔雷斯可供三种类型的双联泵：轴承式、轴瓦式和外接式。外接式可以将任何类型的泵接在前泵的后面，而轴承式和轴瓦式只能后接与其同一类型的泵。

轴承式双联齿轮泵

- 同一传动轴
- 两个进油口
- 前后泵均为轴承式齿轮泵

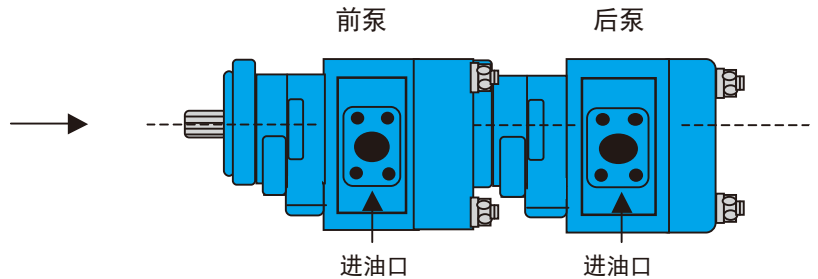

轴瓦式双联齿轮泵

- 同一传动轴
- 一个进油口
- 前后泵均为轴瓦式齿轮泵

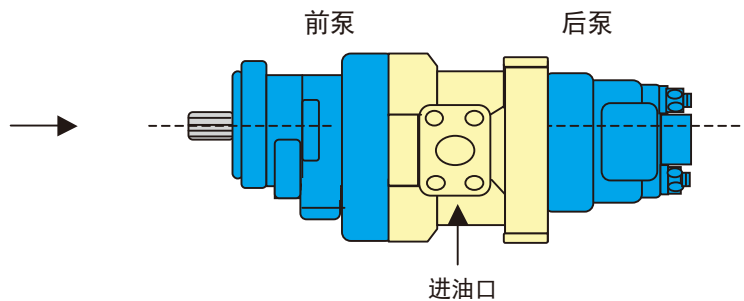

外接式双联齿轮泵

- 同一传动轴
- 两个进油口
- 前后泵可为任何类型的泵

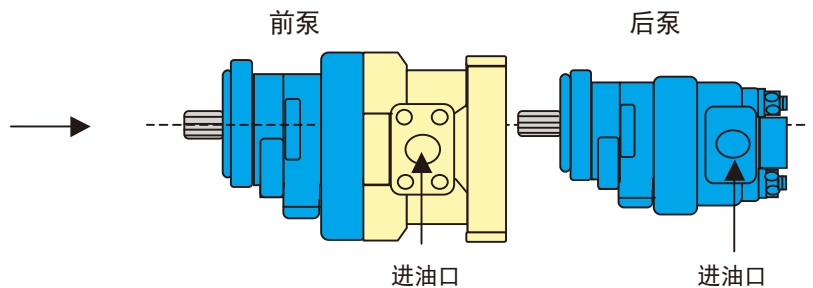

轴承式双联泵	
前泵	后泵
MHP75	MHP50
MHP75	MHP30
MHP76	MHP51
MHP76	MHP31
MHP50	MHP50
MHP50	MHP30
MHP51	MHP51
MHP51	MHP31
MHP30	MHP30
MHP31	MHP31

轴瓦式双联泵	
前泵	后泵
MHP365	MHP330
MHP350	MHP315
MHP330	MHP315

外接式双联泵	
前泵	后泵安装法兰
MHP365	SAE"A"型
MHP365	SAE"B"型
MHP350	SAE"A"型
MHP350	SAE"B"型

质保条款

质保条款：

本公司保证产品在12个月的使用期内，当产品在按工厂规定的技术范围进行正常使用时，产品不会发生材质或加工上的任何缺陷。

质保的限定条款：

本质保限定条款和程序替代一切其它的质保承诺。

根据本质保限定条款，对于买方的全部补偿仅限于对质保产品根据我们的确定作出维修或更换。产品的送交地点为本公司工厂或指定的服务中心。

质保不负责对特殊的偶发的或重大的损失补偿。本公司不对偶发的损失负责，此类损失包括，但不限于诸如失去生命、人身伤害、庄稼损坏、水、火造成的损失、生意的损失或生意收益的损失、停工损失、为其它因产品失效引起的连带商业损失。本公司在任何情况下不对超过产品价格部分的损失负责。

产品的退回必须事先得到本公司的许可。买方或买方代理必须预付所有将该产品退回到本公司工厂或指定服务中心的运费。根据本质保条款，本公司不负责因维修或更换产品所耗费的拆装人工费用和拆装中发生任何意外零件损坏的费用。

以上的质保条款不包括那些本公司无法控制的情形，如油液污染、压力超过推荐的最高工作压力值、产品因偶然的超负载使用或错误使用而损坏、产品未经本公司工作人员或本公司书面授权的人员、而是由其它人员进行了更改或修理等。

任何享受质保的产品在退回前必须先从本公司或本公司授权的服务中心或代理商处得到一个授权号码。

上海毅鸥流体控制技术有限公司
麦塔雷斯（上海）国际贸易有限公司

毅鸥流体代理的其他产品



铝合金齿轮泵及马达

排量范围：0.2~250cc/rev
最高工作压力：280bar
峰值压力：300bar



铸铁齿轮分流器
单元流量：15~230L/min
最高工作压力：245bar

铝合金齿轮分流器
单元流量：5.7~81.2L/min
最高工作压力：280bar

高精度齿轮分流器
单元流量：1.5~90L/min
最高工作压力：350bar

多种组合单元数可供选择



MA10V变量柱塞泵

排量范围：18、28、45、
60、71、100、
140cc/rev
工作压力：280bar
最高工作压力：350bar



管路清洗设备

手持式发射枪及其套件
台式清洗枪
弹丸检测系统

管端密封系统
快速法兰堵盖
干燥呼吸器

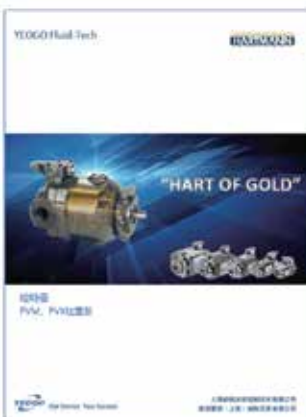

哈特曼柱塞泵

PVM系列
排量范围：0.8~8cc/rev
最高额定压力：280bar

PVX系列
5种结构尺寸
排量范围：10~190cc/rev
最高额定压力：350bar



叶片泵

V10、V20F/P系列
20、25、35、45V/VQ系列
排量范围：6.6~193cc/rev
最高工作压力：210bar



美国进口
MA10V变量柱塞泵
定量叶片泵
铸铁齿轮泵/马达
铸铁齿轮流量分配器



罗马尼亚进口
铝合金齿轮泵/马达
铝合金齿轮流量分配器



英国进口
高精度齿轮流量分配器



罗马尼亚进口
铝合金齿轮泵/马达



美国进口
哈特曼PVM/PVX柱塞泵



美国进口
气动管路清洗设备



意大利进口
铝合金齿轮泵/马达
铝合金齿轮流量分配器



土耳其进口
铸铁齿轮泵/马达
定量柱塞泵



土耳其进口
铝合金齿轮泵/马达
铸铁齿轮泵/马达
铝合金齿轮流量分配器



丹麦品牌
液压泵/马达/阀
Editron电机/变频器
无线遥控/手柄/控制器



上海毅鸥流体控制技术有限公司
麦塔雷斯（上海）国际贸易有限公司
上海市松江区茸华路1155号2号楼203室
电话：86-21-62254024 62111839
电子信箱：sales@yeogo.com.cn
公司网址：www.yeogo.com.cn